

Bank Note Paper Mill India Private Limited
Registered & Corporate office: Paper Mill Compound,
Entry Gate 1, Note Mudran Nagar,
Mysore-570003
CIN: U21090KA2010PTC055475.
NATIONAL COMPETITIVE BIDDING (NCB) –OPEN TENDER
(e-tender)
Standard Biding Document (SBD)

Not transferable
Security classification: Non security

Tender Document for –**Construction of watch tower (1 no.) at BNPM premises, Mysore.**

e-Tender No. BNPM/TEN/392/watchtower/2018-19 Dated 06.08.2018.

The Tender Document **VOL-1** contains 108 Pages

The Tender Document is sold to

M/s
Address

Details of Contact person in BNPM regarding this tender

Name: Alok Kumar

Designation: Deputy General Manager

Address Administrative office Building,
Entry Gate 1, Paper Mill Compound,
Note Mudran Nagar,
Mysore – 570003, Karnataka, India
Phone 0821-2401111
Email info@bnpmindia.com
Website: www.bnpmindia.com



CONTENTS

VOLUME- 1

SL NO	DESCRIPTION	PAGE NUMBER
1	NOTICE INVITING TENDER	3
2	SCOPE OF WORK	6
3	DEFINITION OF TERMS	7
4	GENERAL INSTRUCTIONS TO CONTRACTORS	11
5	SITE FACILITIES	15
6	ELIGIBILITY CRITERIA	16
7	FORM OF TENDER	20
8	GENERAL CONDITIONS OF CONTRACT	23
9	SPECIAL CONDITIONS OF CONTRACT	47
10	SPECIAL INSTRUCTIONS TO TENDERERS	68
11	CONTRACTORS HEALTH AND SAFETY PROGRAMME	68
12	SAFETY CONDITIONS FOR UNDERTAKING SITE WORK	86
13	PROFORMA OF BANK GUARANTEE FOR SECURITY DEPOSIT	97
14	PROFORMA OF BANK GUARANTEE FOR EMD- Not applicable	99
15	SCHEDULE OF DEVIATIONS FROM GENERAL CONDITIONS	100
16	SCHEDULE OF PRICE	101
17	TECHNICAL SPECIFICATIONS	105
17	TENDER DRAWINGS	106



NOTICE INVITING TENDER

BANK NOTE PAPER MILL INDIA PRIVATE LIMITED

Paper Mill Compound, Note Mudran Nagar
Mysore-570003

Tele: 0821-2401 111/191; Fax No: 0821-2581 154

Email info@bnpmindia.com/raghavendra@bnpmindia.com , website: www.bnpmindia.com

(Name, address, telephone no., Fax, e-mail, website etc. of the Unit)

e-Tender No. BNPM/TEN/392/watchtower/2018-19 Dated 06.08.2018.

1. Bidders satisfying the technical and commercial conditions specified in the bid and ready to supply the mentioned products in conformity with the Scope of Supply and Technical specification provided in NIT and terms and conditions stipulated herein may submit their commercial quotes as specified in the format of the document. **The closed quote should be submitted electronically only on the BNPM e-Tendering Portal www.tenderwizard.com/BNP within the time.**
2. Tenders are invited in two parts (Techno-commercial & Financial) from eligible and qualified tenderers for supply of following Goods:

Sl.No	Brief Description of Goods/ Services	Qty With units	Earnest Money Deposit (Rs.)*
1	Construction of watch tower (1 no.) at BNPM premises, Mysore.	As per schedule of price.	Twenty Thousand only (20,000)

*The tenderers who are currently registered and, also, will continue to remain registered during the tender validity period with DGS&D or with National Small Industries Corporation, New Delhi /MSME are exempted from payment of earnest money. In case the tenderer falls in these categories, it should furnish certified copy of its valid registration details (with DGS&D or NSIC or MSME as the case may be).



Tender Number	e-Tender No. BNPM/TEN/392/watchtower/2018-19 Dated 06.08.2018
Type of Tender (Two Bid/PQB/EOI Etc.)	Two Bid
Tender processing fee	Rs 1000/- plus taxes
Closing date and time for receipt of tenders	06.09.2018 1500 hours.
Bid Submission Mode	Through e-tendering portal www.tenderwizard.com/BNP
Time and date of opening of Techno-commercial bid	06.09.2018 1530 hours.

3. Interested tenderers may obtain further information about this requirement from the above office selling the documents. They may also visit our website www.tenderwizard.com/BNP mentioned above for further details.
4. Non-refundable Tender processing fee is Rs. 1,000/- per set plus applicable taxes. The payment shall be made through Electronic mode only.
5. Aspiring Bidders/Contractors who have not registered in e-tendering should register through the website E - Tendering (www.tenderwizard.com/BNP) for participating in the Online Tenders. The registration charges will be Rs. 1,500/- plus applicable taxes (per year) which needs to be paid through electronic mode only.
6. For details, registration and e-payment, please visit e-tendering website www.tenderwizard.com/BNP or contact e-tendering Helpdesk at 080-49352000 /9686115324
7. The NIT Form with standard tender documents will be accessible in the e-Tendering website (www.tenderwizard.com/BNP).
8. Class III Digital Signature Certificate (DSC) is mandatory to participate in e-Tenders. Participating bidders/Contractors have to make sure that they have the valid DSC. If not, they can procure from any of the RAs approved by CCA.
9. Bidders/Contractors should upload and attach all the Scanned copies of technical documents / certificates in e-tendering website www.tenderwizard.com/BNP pertaining to their eligibility criteria mentioned in the NIT, failing which, the bid will not be considered.
10. For those tenderers whose technical bids do not satisfy the eligibility criteria, their financial Bids will not be opened.
11. The tender shall contain two bid systems each of whose contents shall be as follows.

Prequalification Bid & Techno-commercial Bid should consist of clearly visible scanned copy of:



- i) Bid forwarding letter.
- ii) Power of Attorney in favour of the person who has signed the bid on stamp paper of Rs.100/- (non-judicial)
- iii) Documents to establish conformity with Bidder's Qualification / Eligibility criteria.
- iv) PAN details and GST registration certificate,
- v) ESI and EPF registration certificate,
- vi) Earnest Money Deposit (To be paid through electronic mode only to (A/c No. Bank Note Paper Mill India Pvt Ltd, A/c No. : 05230350002465, IFSC Code: HDFC0000523, Branch: Richmond Road Bangalore).
- vii) Deviations from GCC, SCC, SIT, GIT if any,
- viii) Schedule of deviations to technical specifications separately if any,
- ix) Technical details / documents specified in technical part
- x) Blank copy (Without price) of Schedule of price duly signed & stamped on each page

The bidder should submit the "Prequalification Bid & Techno-Commercial bid" in e-tendering portal.

Financial Bid shall contain.

- i) Schedule of Prices duly filled in.

The bidder should submit the- "Financial Bid" in e-tendering portal.

12. Tenderers shall ensure that their tenders (tender documents each & every page shall be), duly stamped and signed, complete in all respects as per instructions contained in the Tender Documents, should be uploaded in e-tendering portal (www.tenderwizard.com/BNP) only.
13. In the event of any of the above mentioned dates being declared as a holiday / closed day for the purchase organisation, the tenders will be sold / received / opened on the next working day at the appointed time.
14. The tender documents are not transferable.
15. Tenders shall remain valid for a period of 3 (Three) months from the date of opening the Part-I Technical Bid, which may be extended by mutual agreement and the BIDDER shall not cancel or withdraw the tender during this period.

Yours Faithfully,

(Alok Kumar)
Deputy General Manager



1. SCOPE OF WORK

1.1 The scope of work shall comprise of, but not limited to water proofing works and construction of watch tower (1 no.) in the premises of Bank Note Paper Mill.

1.2 The civil and structural works covered under the scope of work are listed below:

- (a) Excavation works
- (b) PCC & RCC and allied works.
- (c) General building works
- (d) Finishing works
- (e) Structural steel works
- (f) And other misc. civil works as per the schedule of items

1.3 It is not the intent to specify completely herein all details of design and construction of the works covered under this enquiry. Scope of work may also include such other related works as indicated in the drawings and /or schedule of quantities although they may not be specifically mentioned in the above paragraphs and all such incidental items of works not specified but reasonably implied and necessary for completion of the job as a whole, as directed by OWNER and as directed hereunder. All works shall conform in all respects to high standards of engineering, design and workmanship and shall, fulfil the anticipated performance during the CONTRACTOR's guarantee period in a manner acceptable to the OWNER who shall have the power to reject any works or materials which in his judgement are not in full accordance with the specification requirements as directed hereunder. In case of any conflict regarding the interpretation of the intent or meaning of the specifications or drawings, by OWNER shall interpret such intent or meaning, which will be final and binding on the CONTRACTOR.

1.4 Various works covered in this specification shall include furnishing of all materials, labour, setting out, locating the building or structures, tools plants and equipment's, transportation, fabrication, supervision and construction as per construction drawings including embedment of inserts, bolts etc. leaving pockets, holes, grooves, chambers etc. as shown herein and as directed by or OWNER .

1.5 OWNER reserves the right to split the contract, however the rates/ prices shall remain valid.

1.6 The works covered under the present scope is located within BNPM premises at Mysore. The BIDDER is therefore advised to visit the site and get himself familiar with the site conditions before submission of his offer. No claim by the BIDDER, for increase in prices on this account shall be further entertained.



1.7 Time Of Completion

1.8 The completion of the activities in a time bound manner is the principal requirement as far as the civil construction contract is concerned. The requirement would be to carry out the job uninterruptedly, irrespective of the seasonal changes and also to work during extended hours during the working days/ holidays to achieve the schedule. The CONTRACTOR should note that the entire work shall be completed within a **time period of 03 (Three) months**, failing which, liquidated damages as per General Conditions of Contract will be applicable.

1.9 Work covered under this tender shall be completed within the above time scheduled from the date of Letter of Intent (LOI)/issue of Work order.

1.10 BIDDER shall submit a construction bar chart including all activities keeping in mind the total period of completion as indicated above. The priority of carrying out the civil works shall be decided after mutual discussion with the OWNER.

3 DEFINITION OF TERMS

3.1 'OWNER ' shall mean the client which is **Bank Note Pape Mill India Private Limited** on whose behalf the enquiry is issued by BNPM and shall include its successors and assigns, as well as its authorised officers/representatives.

3.2 'BIDDER' shall mean the firm/party who quotes against this enquiry.

3.3 'VENDOR/CONTRACTOR/FABRICATOR' shall mean the successful BIDDER whose Bid has been accepted by the OWNER and shall include his heirs, legal representatives, successors and assigns.

3.4 'SUB-VENDOR/SUB-CONTRACTOR/SUB-FABRICATOR' shall mean the person named in the 'Contract' undertaking a part of the work or any person to whom a part of the 'Contract' has been sublet with the consent in writing of the OWNER and shall include his heirs legal representatives, successors and assigns.

3.5 'MANUFACTURER' refers to a person or firm who is the producer and furnisher of the material or designer and fabricator of equipment to either the OWNER or the VENDOR/CONTRACTOR or both under the 'Contract'.

3.6 'OTHERS' shall mean other successful BIDDERS whose Bids have been accepted by the OWNER and to whom the orders have been placed by the OWNER and shall include their heirs, legal representatives, successors, and assigns.

3.7 'INSPECTOR' shall mean the authorised representatives appointed by the OWNER for purposes of inspection of Materials/Equipment/Works.

3.8 'Project' shall mean the Construction of Armoury House.



- 3.9 'Site' shall mean the actual place of the proposed 'Project' as detailed in the 'Specification' or other place where work has to be executed under the Contract.
- 3.10 'Month' shall mean the calendar month.
- 3.11 'Specification' shall mean collectively the complete tender document including covering letter issued by the OWNER for inviting bids and such Amendments, Revisions, Deletions or Additions, as may be made subsequently in writing pertaining to the method and manner of performing the work or to the quantities and qualities of the materials to be furnished under this 'Contract'. If any particular work or part or portion thereof is not covered by the 'Specification', the specification for such work shall mean the relevant Bureau of Indian Standards Specification for or relative to the particular work or part or portion thereof shall mean standard engineering practice approved in writing by the ENGINEER/ with or without modification.
- 3.12 'Bid shall mean the proposal/document that the BIDDER submits in the requested and specified form in the tender.
- 3.13 'Plant' or 'Equipment' and 'Work' or 'Works' shall mean respectively the goods to be supplied and services to be provided by the VENDOR/CONTRACTOR/FABRICATOR under the 'Purchase Order' or 'Contract'.
- 3.14 'Contract' or 'Purchase/work Order' shall mean the order and associated specifications executed by the OWNER and the VENDOR/CONTRACTOR including other documents agreed between the parties or implied to form a part of the 'Contract'. The 'contract' may be or may not be formal and registered.
- 3.15 'Contract Price' shall mean the Total amount as calculated from quoted unit rates and estimated quantities (considering extent of variation) for various items of work as set out in the Schedule of Quantities attached to the Contract Agreement/Work Order.
- 3.16 'Effective Date of Contract' shall mean the Calendar date on which OWNER have issued to VENDOR/CONTRACTOR the 'Letter of Intent' or any other date agreed between the OWNER and the BIDDER and specifically mentioned in the Letter of Intent/Work Order/Purchase Order/Contract.
- 3.17 'Contract Period' shall mean the period during which the 'Contract' shall be executed as agreed between VENDOR/CONTRACTOR/FABRICATOR and OWNER in the 'Contract' and it starts with the Effective Date of Contract.
- 3.18 'Guarantee Period' shall mean the period during which the 'Plant' or 'Equipment' shall give the same performance as guaranteed by the VENDOR/CONTRACTOR in the Schedule of Guarantee as in the 'Specification'.
- 3.19 'Approved' and 'Approval' where used in the 'Specification' shall mean, respectively, approved by and approval of the OWNER.



- 3.20 When the works 'Approved', 'Approval', 'Subject to Approval', 'Satisfactory', 'Equal to', 'Proper', 'Requested', 'As directed', 'Where Directed', 'When Directed', 'Determined By', 'Accepted', 'Permitted', or words and phrases of like importance are used, the approval judgement, direction, etc. is understood to be a function of the OWNER .
- 3.21 ENGINEER'S instructions shall mean details, directions and explanations issued by the ENGINEER/ or the OWNER in writing, and drawings(s) and/or oral instructions to be ratified in writing within 48 (forty eight) hours from time to time during the Contract Period.
- 3.22 'Writing' shall include any manuscript, typewritten or printed statement under or over signature and/or seal as the case may be.
- 3.23 'Notice in writing' or 'Written Notice' shall mean a notice in written, typed or printed characters sent by Fax/ Email/ registered post (unless delivered personally or otherwise proved to have been received) to the last known private or business address or registered office of the addressee and shall be deemed to have been received when in the ordinary course of post it would have been delivered.
- 3.24 'CONTRACTOR'S Works' or 'MANUFACTURER'S Works shall mean and include the land and other places which are used by the VENDOR/ CONTRACTOR/FABRICATOR or SUB-VENDOR/SUB-CONTRACTOR/SUB-FABRICATOR for the manufacture of 'Equipment' or performing the 'Works'.
- 3.25 'Commercial Use' shall mean that use of the 'Equipment' or 'Work', which the 'Contract' contemplates, or that for which 'Equipment' or 'Work' is commercially capable.
- 3.26 'Minor Modification', as applied to equipment erection contracts only, shall mean the modification work required to be done on the 'Equipment' and 'Works' which need a maximum of 48 man-hours per item of work. In the case of civil contracts, it shall be 'Works' which need a maximum of 8 man-hours per item of work.
- 3.27 'Major Modification' as applied to equipment erection contracts only, shall mean the modification work required to be done on the 'Equipment' and 'Works' needing more than 48 man-hours per item of work, where such work is required to be done for no fault of the VENDOR/CONTRACTOR. In the case of civil contracts, it shall be 'Works' needing more than 8 man-hours per item of work.
- 3.28 Words importing persons shall include Firms, Companies, Corporations and other Bodies, whether incorporated or not.
- 3.29 'Drawings' shall mean all:
- (a) Drawings furnished by the OWNER as a basis for proposals;
 - (b) Supplementary drawings furnished by the OWNER to clarify and to define in greater detail the intent of the 'Contract';
 - (c) Drawings submitted by the CONTRACTOR with his proposal provided such drawings



are acceptable to the OWNER.

- (d) Drawings furnished by the OWNER to the CONTRACTOR during the progress of the work.
 - (e) Engineering data and drawings submitted by the CONTRACTOR during the progress of the work provided such drawings are acceptable to the OWNER.
- 3.30 'Act of Insolvency' shall mean any Act of Insolvency as defined by the Presidency Towns Insolvency act, or the Provisional Insolvency Act or any amending statute.
- 3.31 There are certain synonyms being used by the OWNER for identification of different buildings / units / divisions / operations. These synonyms shall have their related meanings as being practised or conventional to the OWNER.
- 3.32 Wherever figures are given in this Contract under the word "Elevation" or an abbreviation of it, or where figures representing elevations are given, they shall mean the elevation relative to the arbitrary permanent bench mark fixed by the ENGINEER or OWNER, for the particular work, located as shown on site plan or a datum level established OWNER.
- 3.33 Structure of the Tender Specifications.
- 3.33.1 The BIDDER shall be deemed to have carefully examined the 'Specification' in its complete form and to have fully informed and satisfied himself as to the details, nature, character and quantities of the work to be carried out, site conditions and other pertinent matters and details.
- 3.33.2 It is the intent of the OWNER to incorporate these specification documents in the final 'Contract' or 'Purchase Order' for the supply of material, equipment and services. The BIDDERS are required to review these documents and clearly state exceptions, if any. However no deviations will be allowed. The final 'Contract' between the OWNER and the VENDOR/CONTRACTOR shall be subjected to such changes, if any, mutually agreed upon between the OWNER and the VENDOR/CONTRACTOR and included in the main text of the 'Contract' or 'Purchase Order'.

4 GENERAL INSTRUCTIONS TO CONTRACTORS

- 4.1 The Techno-commercial Bid will be opened at **1530 on September 06, 2018** at our e-tender portal.
- 4.2 Tenders shall remain valid for a period of **3 (Three) months** from the date of opening the techno-commercial Bid, which may be extended by mutual agreement and the BIDDER shall not cancel or withdraw the tender during this period.
- 4.3 The BIDDER must use only the **e-tender portal to fill in the rates under price bid.**
- 4.4 Each of the tender documents should be signed by the person or persons submitting the



tender in token of his/their acquainted himself/themselves with the General Conditions of Contract, Specifications, Special Conditions, etc. as laid down. Any tender with any of the documents not signed may be rejected.

- 4.5 The tender submitted on behalf of a firm shall be signed by all the partners of the firm or by a partner who has the necessary authority on behalf of the firm to enter into the proposed contract. Otherwise the tender may be rejected by OWNER.
- 4.6 The OWNER does not bind itself to accept, the lowest or any tender and reserve to itself the right to accept or reject any or all the tenders, either in whole or in part, without assigning any reasons for doing so.
- 4.7 Intending BIDDERS shall pay as Earnest Money Deposit a sum of **Rs. 20,000/- (Rupees Twenty Thousand only)** by Electronic fund transfer. The Earnest Money will be refunded to the BIDDER if his tender is not accepted but without any interest. No interest shall be paid on the said deposit.
- 4.8 Under no circumstances Earnest Money Deposit will be accepted in the form of fixed deposit receipt of Bank or Insurance Guarantee or Cheque.
- 4.9 The **Earnest Money Deposit of Rs. 20,000/- (Rupees Twenty Thousand only)** to be paid by BIDDER in the form of Electronic fund transfer to A/c No. Bank Note Paper Mill India Pvt Ltd, A/c No. : 05230350002465, IFSC Code: HDFC0000523, Branch: Richmond Road Bangalore when he submits his tender shall be held by the OWNER as security for the execution and due fulfilment of the contract till he completes the work. No interest shall be paid on the said deposit. **The same shall be released on submission of BG within 21 days after issue of LOI/WO towards Security deposit for 10 % of the contract value if the contract is awarded to bidder.**
- 4.10 If the tenderer is registered under DGS&D/NSIC/MSME, they have to clearly mention and submit a copy of supporting documents. In absence of any such declaration, tenderer shall be considered as not registered under DGS&D/NSIC/MSME. Tenderer registered with NSIC/DGS&D/MSME are eligible for exemption of only EMD. **As regarding SD, the tenderer who are registered with DGS&D /NSIC/MSME should submit an undertaking for payment of Security Deposit in case they become L1 firm in bid process and this undertaking letter should be attached to the technical bid.**
- 4.11 All compensation or other sums of money payable by the CONTRACTOR to the OWNER under the terms of this Contract may be deducted from the security deposit if the amount so permits and the CONTRACTOR shall, unless such deposit has become otherwise payable, within ten days after such deduction make good in cash the amount so deducted.
- 4.12 The CONTRACTOR shall carry out all the work strictly in accordance with drawings, details and instructions of the OWNER. If in the opinion of the ENGINEER, any changes have to be made in the design, and with the prior approval in writing of the OWNER, they desire the CONTRACTOR to carry out the same, the CONTRACTOR shall carry out the same without



any extra charge. The OWNER decision in such cases shall be final and shall not be open to arbitration.

- 4.13 A Schedule of Probable Quantities in respect of each work and Specification accompany these Special Conditions. The Schedule of Probable Quantities is liable to alteration by omissions, deductions or additions at the discretion of the OWNER. Each Part II Commercial Bid should contain not only the rates but also the value of each item of work entered in a separate column and all the items should be totalled in order to show the aggregate value of the entire tender.
- 4.14 The BIDDER must obtain for himself on his own responsibility and at his own expenses, all the information which may be necessary for the purpose of making a tender and for entering into a contract and must examine the drawings and must inspect the site of the work and acquaint himself with all local conditions, means of access to the work, nature of the work and all matters appertaining thereof.

The rates quoted in the tender shall include all charges for clearing of site before commencement as well as after completion, water, electric consumption, meters, double scaffolding, centering, boxing, staging, planking, timbering and pumping out water including bailing, fencing, hoarding, plant and equipment, storage sheds, watching and lighting by night as well as day including Sundays and holidays, temporary plumbing and electric supply, protection of the public and safety of adjacent roads, streets, cellars, vaults, ovens, pavements, walls, houses, buildings and all other erections, matters or things and the CONTRACTOR shall take down and remove any or all such centering, scaffolding, staging, planking, timbering, strutting, shoring etc. as occasion shall require or when ordered so to do and fully reinstate and make good all matters and things disturbed during the execution of work and to the satisfaction of the OWNER . The rates quoted shall be deemed to be for the finished work to be measured at site. The rates shall also be firm and shall not be subject to exchange variations, labour conditions, fluctuations in railway freights or any conditions whatsoever. Tenderers must include GST in their rates. Any change in tax part shall also be reimbursable.

The successful tenderers may also note that the OWNER reserves the right to deduct applicable taxes from the bills and amount due to them from Bank and remit the same directly to the Government in case they are not submitting the proof/evidence of having paid the Taxes on work executed under this contract

- 4.15 The rates quoted shall be firm for the entire duration of contract including the period of extension.
- 4.16 The CONTRACTOR should note that unless otherwise stated, the tender is strictly on item rates basis and his attention is drawn to the fact that rates for each and every item should be correct, workable and self-supporting. The quantities in the Schedule of Quantities approximately indicate the total extent of work, but may vary to any extent and may even



be omitted thus altering the aggregate value of the Contract. Rates quoted shall remain firm.

- 4.17 Time allowed for carrying out the work as mentioned in the tender shall be strictly observed by the CONTRACTOR and it shall be reckoned from the date of issue of LOI.
- 4.18 The work shall throughout the stipulated period of the contract be proceeded with all due diligence and if the CONTRACTOR fails to complete the work within the specified period, he shall be liable to pay compensation as defined in General Conditions of Contract. The BIDDER shall before commencing work prepare a detailed work programme which shall be approved by the OWNER.
- 4.19 Tenders will be considered only from Interested CONTRACTORS.
- 4.20 The CONTRACTOR shall not be entitled to any compensation for any loss suffered by him on account of delays in commencing or executing the work, whatever the cause of delays may be, including delays arising out of modifications to the work entrusted to him or in any sub-contract connected therewith or delays in awarding contracts for other trades of the project or in commencement or completion of such works or in procuring Government controlled or other building materials or in obtaining water and power connections for construction purposes or for any other reason whatsoever and the OWNER shall not be liable for any claim in respect thereof. The OWNER does not accept liability for any sum besides the tender amount, subject to such variations as are provided for herein.
- 4.21 The successful BIDDER is bound to carry out any items of work necessary for the completion of the job even though such items are not included in the quantities and rates. Schedule of instructions in respect of such additional items and their quantities will be issued in writing with the prior consent in writing of the OWNER.
- 4.22 The successful BIDDER must co-operate with the other CONTRACTORS appointed by the OWNER so that the work shall proceed smoothly with the least possible delay and to the satisfaction of the s.
- 4.23 The CONTRACTOR must bear in mind that all the work shall be carried out strictly in accordance with the Specifications made by the OWNER and also in compliance of the requirements of the local public authorities and statutory authorities and no deviation on any account will be permitted. In the event of any default on this account the CONTRACTOR shall at his cost rectify to the satisfaction of the concerned statutory authority. In the case of his failure to do so the same shall be got done by the OWNER through any other agency at the risk and cost of the CONTRACTOR.
- 4.24 The successful BIDDER should make his own arrangement to obtain all materials required for the work including cement and steel etc.
- 4.25 All Municipal fees for drainage and water connection for construction purposes shall be borne by the CONTRACTOR and fees if any payable for permanent connections shall be



initially paid by the CONTRACTOR and the OWNER will reimburse the amount on production of receipts.

- 4.26 The CONTRACTOR shall strictly comply with the provision of safety code attached herewith.
- 4.27 IS Code numbers wherever mentioned in the tender shall be the latest version of IS codes as on the date of opening of tenders.
- 4.28 The successful BIDDER shall be required to submit the PERT/CPM chart for the various activities involved in this work including dependencies etc. and regularly monitor the progress of construction accordingly.
- 4.29 The security deposit of the successful BIDDER will be forfeited if he fails to comply with any of the conditions of the Contract.
- 4.30 CONTRACTOR to inform himself fully. The CONTRACTOR shall be deemed to have carefully examined the work and site conditions including labour, the general and special conditions, the specifications, schedules, drawings and shall be deemed to have visited the site of work, to have fully informed himself regarding the local conditions and carried out his own investigations to arrive at the rates quoted in the tender. In this regard he will be given necessary information available with the OWNER but without any guarantee about its accuracy.
- 4.31 If the CONTRACTOR shall have any doubt as to the meaning of any portion of the general conditions, or the special conditions or the scope of the work or the specifications and drawings or any other matter concerning the contract he shall in good time, before submitting his tender, put forth the particulars thereof and submit them to OWNER in writing in order that such doubts may be clarified authoritatively in writing before tendering.
- 4.32 Record note of discussion on important issues including copies of the question raised and the responses given will be made available to all BIDDERS. These record notes shall be only for clarification and shall not modify the tender document conditions. However, as a result of pre-bid conference, if any modification in tender document is warranted, the same shall be made available to the BIDDER through a issuance of addendum (and not through the minutes of pre-bid conference), which will be communicated in writing. Once a tender is submitted the matter will be decided according to tender conditions in the absence of such authentic pre-clarification.
- 4.33 Errors, Omission and Descriptions

In case of errors, omissions and/or disagreement between written and scaled dimensions on the drawings or between the drawings and specification etc. the following order of preferences shall apply.

- (a) Between actual scaled and written dimension (or description) on a drawing the



latter shall be adopted.

- (b) Between the written or shown description or dimensions in the drawings and the corresponding one in the specification the latter shall be taken as correct.
- (c) Between the written description of the item in the specifications and the detailed descriptions in the schedule of quantities of the same item, the latter shall be adopted.

4.34 Between the duplicate/subsequent copies of the tender and original tender, the original shall be taken as correct.

4.35 In all cases of omissions and/or doubts or discrepancies in any item or specification a reference shall be made to the OWNER whose elucidation, elaboration or decision shall be considered as authentic. The CONTRACTOR shall be held responsible for any errors that may occur in the work through lack of such reference and precaution.

5 SITE FACILITIES

The following facilities will be provided by the OWNER in good faith at terms indicated hereunder. No claims, whatsoever, arising out of use, misuse or failure of these facilities will be entertained.

5.1 Construction Water

Construction water shall be arranged by the OWNER at one point. The distribution with all necessary accessories shall be arranged by contractor.

5.2 Construction Power

Construction Power shall be arranged by the OWNER at one point. Necessary arrangements may be taken care by CONTRACTOR.

5.3 Open Space

NO open space shall be provided except for storage of materials near to the work area/owner premises as directed by engineer in charge.

Site shall be handed over to the OWNER in a clean and tidy conditions on completion of 'Work' or as instructed by the OWNER failing which the Work Completion Certificate will not be issued.

5.4 It is the responsibility of the CONTRACTOR to make suitable arrangements for the following:

- (a) Portable compressors, pumps, temporary piping and accessories as required for cleaning, testing, flushing etc.



- (b) Accommodation
- (c) Workshop Facilities - to carry out site fabrication as may be required.
- (d) Canteen Facilities for his personnel.

5.5 Consumables

All consumables and expendables required for work under this contract including necessary welding electrodes shall be arranged by the CONTRACTOR.

5.6 Lighting

The CONTRACTOR will make his own arrangement for lighting for carrying out work at night as required. Only general lighting of the area as already available shall be maintained by the OWNER.

Qualification/ Eligibility Criteria

For Part-I: Technical Bid Criteria: _

The pre-qualification criteria for the same are given as under: Individual/ firm/ company/ corporate other than limited company intending to bid should be bonafide, experienced, technically competent, resourceful and financially sound to carry out the assigned order.

The bidder should be:-

- a) Registered under GST.
- b) Having valid permanent Income Tax A/c No. as allotted by the Income Tax Authority of Government of India.
- c) Not blacklisted/ debarred by BNPM/ Bharatiya Reserve Bank Note Mudran (P) Limited (BRBNMPL) / Security Printing & Minting Corporation of India Limited (SPMCIL) or any Govt. Departments for participation in tender.

Experience & Past Performance	<p>Bidder shall have successfully completed the similar works during the last 5 years period ending 31.07.2018.</p> <p>Three similar works each costing not less the amount of Rs 4.0 lakhs in the last 5 years up to 31.07.2018.</p> <p>OR</p> <p>Two similar works each costing not less than the amount of Rs 5.0 lakhs in the last 5 years up to 31.07.2018.</p> <p>OR</p> <p>One similar works each costing not less than the amount of Rs 8.0 lakhs in the last 5 years up to 31.07.2018.</p>
-------------------------------	--



	<p>Documentary proof for the same shall be enclosed in the offer such as work completion certificate/work orders, value of the works shall be mentioned.</p> <p>Note: Similar works building constructions & other civil works in Educational/institutional/residential/industrial/commercial buildings etc.</p>
Financial Standing	<p>Average annual turnover of the bidder firm during last three years period ending 31-03-2018 should be more than Rs. 03 lakhs/-(Rupees Seven Lakhs only)</p> <p>Bidder Firms should not have suffered any financial loss for more than one year during the last three years period ending 31.03.2018.</p> <p>The net worth of the firm should not be in negative and should have not eroded by more than 30% in the last three years period ending 31.03.2017.(i.e. 2015-16, 16-17 & 17-18)</p>

1. Work order completion certificate indicating Name of works, Name of the client, Work order no., date, Value of works order placed, actual value of work completed and the time period for the completion of the work duly attested copies for each of the works should be submitted along-with the Tender Part – I. If required so the Bidder has to produce the original documents for verification to BNPMIPL, failing which the bidder will be disqualified. The originals of all the above-mentioned documents will be returned back after verification.
 - a. Proof of registration with GST, PAN.
 - b. ESIC and PF Registration Certificates.
 - c. Tenderer should submit ITR, Balance sheet, profit & loss account statements for previous 3 years (Final audited) i.e. for the financial year 2017-18, 16-17 & 2015-16 duly signed/certified by the chartered accountant.
 - d. All the above certificates / documents shall be duly signed with seal by the Authorized person of the firm.
 - e. Power of Attorney / Authorization with the seal of the company in the name of the person signing the Tender Documents.
 - f. Details of the contact person/ (s) with mobile number, email address, fax numbers etc.
 - g. History and Structure of firm name of director / partners / proprietor with technical staff.



- h. Tenderer shall submit a letter of undertaking indicating that detailed time schedule for various activities to complete within the time as stipulated in the work order, Schedule of plan in the form of BAR CHART for the completion of the work showing all activities and incorporating completion schedule for different milestones called for shall also be submitted by the contractor. Since the work is time bound, therefore contractors should plan the various activities in such a way so that the work allotted will be completed in all respect within specified time from the date of issue of work order.
- i. Detail of Civil and criminal cases and other legal dispute proceedings/arbitration proceedings, if any, pending against the tenderer or where the tenderer is involved and also closed cases during the last 5 years is to be informed and the related documents shall be submitted.
- j. Declaration about having read all the tender documents in details and understanding of the same.
- k. Declaration on the firm/company/proprietor about not being relative to the directors of the company.
- l. Declaration on the firm/company/proprietor about not being blacklisted/ debarred by BNPM/ Bharatiya Reserve Bank Note Mudran (P) Limited (BRBNMPL) / Security Printing & Minting Corporation of India Limited (SPMCIL) or any Govt. Departments for participation in tender

Scanned Documents to be uploaded in support of Pre-qualification Criteria in e-portal only.

2. The bidder should meet/satisfy all the conditions stipulated for minimum qualification & eligibility criteria for acceptance of bid for the specified work subjected to evaluation.

All the copies of the above documents shall be self-attested or Notary attested or Gazetted officer.

Price Bid:

The price bid of the bidders who have qualified in techno-commercial only will be opened. The date of opening the price bids shall be intimated to the qualified bidders at the later stages.

Important:

1. *Please note that the contractors who have worked earlier with BNPMIPL and their performance was not found satisfactory for any of the jobs awarded to them, their tenders shall not be opened during technical bid stage and their offers shall be considered as invalid and shall be rejected.*



2. *Issuance of tender paper or submission of tender document shall not automatically be construed qualification of bidder for award of work, which will actually be determined during bid evaluation.*

Note: All documents shall be uploaded on our e-portal after duly signed and sealed.



6 FORM OF TENDER

BIDDER shall submit the 'Form of Tender' in the following format:

Place:

Date:

To

Managing Director,

Bank Note Paper Mill India Private Limited

Note Mudran Nagar,

Mysore 570003.

Dear Sir,

Having examined the drawings, specifications, designs and schedule of quantities relating to the works specified in the tender hereinafter set out and having examined the site of the works specified in the said tender and having acquired the requisite information relating thereto as affecting the tender, I/We hereby offer to execute the works specified in the said tender within the time specified in the said tender at the rates mentioned in the attached schedule of quantities and in accordance in all respects with the specifications, designs, drawings and instructions in writing referred to in Conditions of Tender, the Articles of Agreement, Special Conditions, Schedule of Quantities and General Conditions of Contract and with such materials as are provided for, by and in all other respects in accordance with such conditions so far as they may be applicable.



1.	Description of work	Water proofing works and construction of watch tower (1 no.) at BNPM premises, Mysore.
2.	Defects Liability Period	12 Months after date of completion of work (virtual completion certificate)
3.	Earnest Money Deposit	₹ 20,000/- (Rupees Twenty Thousand only).
4.	Period of Final Measurement	30 days from the date of virtual completion
5.	Date of Commencement of Work	Within 10 days of issue of LOI/WO
6.	Date of Completion	3 months from date of commencement of work
7.	Liquidated Damage	@ 0.5% of the delayed value of the delayed work shall be levied per week delay or part thereof, subject to a maximum of 10% of total value of works completed / final bill value.
8.	Terms & Modes of payment	100% for certified bill amount shall be paid. All payment made towards RA bills shall be considered as advance against the final payment.
9.	Value of works for interim certified running account payment	Rs. 5 Lakhs (100% for certified running account bill amount shall be paid)
10.	Security Deposit	Security deposit shall be submitted in the form of BG for the 10% of contract value which shall be released after completion of DLP and 2 months claim period. BG shall be submitted within 21 days after the issue of LOI/WO.
11.	Period of honouring certificates of payment	20 days for running account bills & 30 days for final bills



Should this tender be accepted, I/We hereby agree to abide by and fulfil the terms and provisions of the said Conditions of Contract, annexed hereto so far as they may be applicable or in default thereof to forfeit and pay to the OWNER the amount mentioned in the said conditions.

I/We have deposited a sum of ₹ 20,000 (Rupees Twenty Thousand only) as Earnest Money Deposit with the OWNER which amount is not to bear any interest. Should I/We fail to execute the contract when called upon to do so, I/We do hereby agree that this sum shall be forfeited by me/us to the OWNER.



8. GENERAL CONDITIONS OF CONTRACT

The Conditions herein before referred to

8.1 In construing these conditions, the Specifications, Schedule of Quantities and Contract Agreement, the following words shall have the meanings herein assigned to them except where the subject or context otherwise requires.

(a) **CONTRACTOR**

In the case of a partnership firm CONTRACTOR shall mean _____

_____ and
_____ trading as partners in the
name and style of _____

_____ and
having a place of business at _____
_____ and
shall include the partners for the time being of
the said firm and the legal representatives of a
deceased partner.

In the case of individual CONTRACTOR shall mean _____
_____ trading in the
name and style of _____

_____ and
shall include his heirs, successors and legal
representatives.

In the case of company CONTRACTOR shall mean _____
_____ a
company incorporated under _____
_____ and having its registered office
at _____ and shall include its
successors and assignees.



- (b) Site Shall mean the site of the contract works including any building and erections thereon and any other land (inclusively) as aforesaid allotted by the OWNER for the CONTRACTOR's use.
- (c) This Contract Shall mean the Articles of Agreement, the Special Conditions, the Conditions, the Appendix, the Schedule of Quantities and Specification attached hereto and duly signed.
- (d) Notice in writing Written notice shall mean a notice in written, typed or printed characters sent (unless delivered personally or otherwise proved to have been received) by FAX/ E- mail/ Registered Post/ Courier to the last known private or business address or registered office of the addressee and shall be deemed to have been received when in the ordinary course of post it would have been delivered.
- (e) Act of Insolvency Shall mean any act of insolvency as defined by the Presidency Towns Insolvency Act or the Provincial Insolvency Act or any Act amending such original.
- (f) Net Prices If in arriving at the contract amount the CONTRACTOR shall have added to or deducted from the total of the items in the Tender any sum, either as a percentage or otherwise, then the net price of any item in tender shall be the sum arrived at by adding or deducting from the actual figure appearing in the Tender as the price of that item a similar percentage or determining the percentage or proportion of the sum so added or deducted by the CONTRACTOR the total amount of any Prime Cost items and provisional sums of money shall be deducted from the total amount of the tender. The expression "net rates" or "net prices" when used with reference to the contract or accounts shall be held to mean rates or prices so arrived at.



(g) Works Shall mean _____

 _____ for
 the OWNER at _____

 _____ as
 provided herein.

Words importing persons include firms and corporations. Words importing the singular only also include the plural and vice versa where the context requires.

8.2 The CONTRACTOR shall carry out and complete the said work in every respect in accordance with this Contract and with the directions of and to the satisfaction of the OWNER. The OWNER may in his absolute discretion and from time to time issue further drawings and/or written instructions, detailed directions and explanations which are hereafter collectively referred to as "s Instructions" in regard to :

- (a) The variation or modification of the design, quality or quantity of works or the addition or omission or substitution of any work.
- (b) Any discrepancy in the drawings or between the Schedule of Quantities and/or drawings and/or specification.
- (c) The removal from the site of any material brought thereon by the CONTRACTOR and the substitution of any other material therefore.
- (d) The removal and/or re-execution of any works executed by the CONTRACTOR.
- (e) The dismissal from the works of any persons employed thereupon.
- (f) The opening up for inspection of any work covered up.
- (g) The amending and making good of any defects.
- (h) The CONTRACTOR shall forthwith comply with and duly execute any work comprised of such "s instructions" provided always that verbal instructions, directions and explanations given to the CONTRACTOR or his representatives upon the works by the shall, if involving a variation, be confirmed in writing by the CONTRACTOR within seven days, and if not



dispensed from in writing within a further seven days by the, such shall be deemed to be Instructions within the scope of the Contract.

8.3 Variations to be approved by OWNER

Notwithstanding anything herein contained, the OWNER may issue any instructions, in verbal or in writing, which will result in the OWNER having to pay the CONTRACTOR an additional sum greater than Rs.2500/- and all instructions issued to the CONTRACTOR should forthwith be brought to the notice of the OWNER. The CONTRACTOR shall submit through the statement of variations giving quantity and rates duly supported by analysis of rates, vouchers etc. The rates on scrutiny and final acceptance by the OWNER shall form a supplementary tender. The OWNER shall not be liable for payment of such variations until these statements are sanctioned by it.

8.4 Drawings and Schedule of Quantities and Agreement

The Contract shall be executed in triplicate and the, the OWNER and the CONTRACTOR shall be entitled to one executed copy each for his use. The CONTRACTOR on the signing hereof shall be furnished by the or OWNER free of cost one copy of each of the said drawings and of the specification and one copy of all further drawings issued during the progress of the works. Any further copies of such drawings required by the CONTRACTOR shall be paid for by him. The CONTRACTOR shall keep one copy of all drawings on the works and the OWNER or his representative shall at all reasonable time have access to the same. Before the issue of the final certificate to the CONTRACTOR he shall forthwith return to the OWNER all drawings and specifications.

8.5 The CONTRACTOR shall provide at his cost everything necessary for the proper execution of the works according to the intent and meaning of the drawings. Schedule of Quantities and Specification taken together with whether the same may or may not be particularly shown or described therein provided that the same can reasonably be inferred there from and if the CONTRACTOR finds any discrepancy in the drawings or between the drawings, Schedule of Quantities and Specifications, he shall immediately and in writing refer same to the OWNER who shall decide which is to be followed.

8.6 Authorities, notices and patents

(a) The CONTRACTOR shall conform to the provision of any Act of the Legislature relating to the work, and to the regulations and bye-laws of any



authority, and of any water, electric supply and other companies and/or authorities with whose systems the structure is proposed to be connected and shall before making any variations from the Drawing or Specifications that may be necessitated by so conforming to the or OWNER written notice, specifying the variation proposed to be made and the reason for making it and apply for instructions thereon. In case the CONTRACTOR shall not within ten days receive such instructions he shall proceed with the work conforming to the provisions, regulations or bye-laws in question, and any variation so necessitated shall be dealt with under Clause 8.14 thereof.

- (b) The CONTRACTOR shall bring to the attention of the OWNER all notices required by the said Acts, regulations or bye-laws to be given to any authority and pay to such authority, or to any public office all fees that may be properly chargeable in respect of the works, and lodge the receipts with the or OWNER .
- (c) The CONTRACTOR shall indemnify the OWNER against all claims in respect of patent rights, and shall defend all actions arising from such claims, and shall himself pay all royalties, licence fees, damages cost and charges of all and every sort that may be legally incurred in respect thereof.

8.7 Setting out of works

The CONTRACTOR shall set out the works and shall be responsible for the true and perfect setting out of the same and for the correctness of the positions, levels, dimensions and alignment of all parts thereof. If at any time any error in this respect shall appear during the progress of the works or within a period of one year from the completion of the works, the CONTRACTOR shall, if so required, at his own expense rectify such error to the satisfaction of the or OWNER .

8.8 Materials and workmanship to conform to descriptions

All materials and workmanship shall so far as procurable be of the respective kinds described in the Schedule of Quantities and/or Specifications and in accordance with the 's instructions, and the CONTRACTOR shall upon the request of the or OWNER furnish him with all invoices, accounts, receipts and other vouchers to prove that the materials comply therewith. The CONTRACTOR shall at his own cost arrange for and/or carry out any test of any materials which the OWNER may require.



8.9 CONTRACTOR's superintendence and representative on the works

The CONTRACTOR shall give all necessary personal superintendence during the execution of the works, and as long thereafter as the OWNER may consider necessary until the expiry of the "Defects Liability Period" stated in the appendix hereto. The CONTRACTOR shall also during the whole time the works are in progress employ a competent, qualified and experienced Engineer who shall be constantly in attendance at the works while the men are at work. Any directions, explanations, instructions or notices given by the OWNER to such representative shall be held to be given to the CONTRACTOR.

8.10 Dismissal of workmen

The CONTRACTOR shall on request of the OWNER immediately dismiss from the works any person employed thereon by him who may, in the opinion of the OWNER, be incompetent or misconduct himself and such persons shall not be again employed on the works without the permission of the OWNER.

8.11 Access to works

The OWNER and their respective representative shall at all reasonable times have free access to the work and/or to the workshops, factories or other places where materials are lying or from which they are being obtained and the CONTRACTOR shall give every facility to the OWNER and their representatives necessary for inspections and examination and test of the materials and workmanship. Only Persons authorized by the OWNER except the representatives of public authorities shall be allowed on the works at any time.

8.12 Inspection of Works

Any representative of the OWNER shall have power to give notice to the CONTRACTOR or to his representative of non-approval of any work or materials and such work shall be suspended or the use of such materials shall be discontinued until the decision of the OWNER is obtained. The work will from time to time be examined by the OWNER. But such examination shall not in any way exonerate the CONTRACTOR from the obligation to remedy any defects which may be found to exist at any stage of the works or after the same is completed. Subject to the limitation of this clause, the CONTRACTOR shall take instructions only from the OWNER.



8.13 Assignment and subrogation

The whole of the works included in the contract shall be executed by the CONTRACTOR and the CONTRACTOR shall not subrogate any work or any part/share thereof or any interest therein without informing in writing to the OWNER. OWNER reserves the right to reject/disapprove such subrogation if the performance of the Sub-CONTRACTOR is found to be not satisfactory by the OWNER. Notwithstanding the above, CONTRACTOR shall take the full and entire responsibility of the Contract and active superintendence of the works during the progress.

8.14 Alterations, additions, omissions etc.

No alterations, omission or variation shall vitiate this Contract but in case the OWNER thinks proper at any time during the progress of the works to make any alterations in, or additions to, or omissions from, the works or any alteration in the kind or quality of the materials to be used therein and shall give notice thereof under his hand to the CONTRACTOR. The CONTRACTOR shall alter, add to, or omit from, as the case may be in accordance with such notice, but the CONTRACTOR shall not do any work extra to or make any alterations or additions to or omissions from the works or any deviation from any of the provisions of the contract, stipulation, specification or contract drawings without the prior consent in writing of the and the value of such extras, alterations, additions or omissions shall in all cases be determined by the with the prior approval in writing of the OWNER in accordance with the provisions of contract thereof, and the same shall be added to or deducted from the Contract Amount, as the case may be.

8.15 Schedule of Quantities

- (a) The Schedule of Quantities, unless otherwise stated shall be deemed to have been prepared in accordance with the standard method of measurement.
- (b) Any error in description or in quantity or in omission of items from the Schedule of Quantities shall not vitiate this contract but shall be rectified and the value thereof, as ascertained in tender thereof, shall be added to, or deducted, from the Contract Amount (as the case may be) provided that no rectification or errors, if any, shall be allowed in the CONTRACTOR'S Schedule of Rates.



8.16 Sufficiency of Schedule of Quantities

The CONTRACTOR shall be deemed to have satisfied himself before tendering as to the correctness and sufficiency of his tender for the works and of the prices stated in the Schedule of Quantities and/or Schedule of Rates and prices which rates and prices shall cover all his obligations under the Contract, and all matters and things necessary for the proper completion of the works.

8.17 Measurement of Works

- (a) The OWNER may from time to time intimate to the CONTRACTOR and the OWNER that he requires the works to be measured and the CONTRACTOR shall forthwith attend or send a qualified engineer to assist the OWNER in taking such measurements and calculations and to furnish all particulars or to give all assistance required by any of them.
- (b) Should the CONTRACTOR not attend or neglect or omit to send such engineer then the measurement taken by the person approved by him shall be taken to be correct measurements of the works. Such measurements shall be taken in accordance with the Mode of Measurements detailed in the Specifications.
- (c) The CONTRACTOR or his engineer may at the time of measurement take such notes and measurements as he may require.
- (d) Any claim, which the CONTRACTOR may have to make in respect of such measurement, shall be made by him in writing to the ENGINEER/ within seven days of date of these measurements, failing which the measurement shall be deemed to have been accepted by the CONTRACTOR.
- (e) All authorized extra works, omissions and all variations made without the knowledge, but subsequently sanctioned by him in writing (with the prior approval in writing of the OWNER) shall be included in such measurements.

8.18 Prices for extras etc. ascertainment of

- (a) The CONTRACTOR may, when authorized, and shall, when directed, in writing by the , with the approval of the OWNER add to, omit from or vary the works shown upon the drawings or described in the specification, or included in the Schedule of Quantities, but the CONTRACTOR shall make no addition, omission or variation without such authorisation or direction. A



verbal authority or direction by the OWNER shall, if confirmed by them in writing within seven days, be deemed to have been given in writing.

- (b) No claim for an extra shall be allowed unless it shall have been executed under provisions tender thereof or by the OWNER as herein mentioned. Any such extra is herein referred to as authorized extra and shall be made in accordance with the following provisions :
- (i) The net rates or prices in the original tender shall determine the valuation of the extra work where such extra work is of similar character and executed under similar conditions as the work priced therein.
- (ii) Rates for all items, wherever possible, should be derived out of the rates given in the Priced Bill of Quantities.
- (c) The net prices of the original tender shall determine the value of the items omitted /provided, if omissions vary the conditions under which any remaining items of works are carried out the prices for the same shall be valued under sub-clause (d) thereof.
- (d) Where the extra works are not of similar character and/or executed under similar conditions as aforesaid or where the omissions vary the conditions under which any remaining items of works are carried out or if the amount of any omissions or additions relative to the amount of the whole of the contract works or to any part thereof shall be such that in the opinion of the or OWNER the net rate or price contained in the Priced Schedule of Quantities or tender or for any item of the works involves loss or expense beyond that reasonably contemplated by the CONTRACTOR or is by reason of such omission or addition rendered unreasonable or inapplicable, the shall fix such other rate or price as in the circumstances he shall think reasonable and proper, with the prior approval in writing of the OWNER .
- (e) Where extra work cannot be properly measured or valued, the CONTRACTOR shall be allowed day work prices as the net rates stated in the tender of the Priced Schedule of Quantities or, if not so stated, then in accordance with the local day work rates and wages for the district, provided that in either case ,vouchers specifying the daily time (and if required by the or OWNER , the workman's name) and materials employed be delivered for verification to the or OWNER or his representative at or before the end of the week following that in which the work has been executed.



- (f) It is further clarified that for all such authorized **extra items** where rates cannot be derived from tender, **the CONTRACTORS shall submit rates supported by rate analysis worked on the “actual cost basis” plus 15%** towards establishment charges, CONTRACTOR’s overhead and profit with documentary evidences such as purchase invoice etc.
- (g) The measurement and valuation in respect of the Contract shall be completed within the “Period of Final Measurement” stated in the Appendix or if not stated then within One month of the completion of the Contract works.
- (h) A variation order for additional items/non-tender/quantity variations of BOQ shall issue by the OWNER for claiming in the bills by contractor. Contractor shall submit the requisition with all the necessary documents for the same.

8.19 Unfixed materials when taken into account to be the property of the OWNER

Where in any Certificate (of which the CONTRACTOR has received payment), the OWNER has included the value of any unfixed materials intended for and/or placed on or adjacent to the works such materials shall become the property of the OWNER and they shall not be removed except for use upon the works, without the written authority of OWNER. The CONTRACTOR shall be liable for any loss of or damage to, such materials.

8.20 Removal of improper work

The OWNER shall, during the progress of works, have power to order in writing from time to time the removal from, the works within such reasonable time or times as may be specified in the order, of any materials which in the opinion of the OWNER are not in accordance with the specifications or instructions of the OWNER. The substitution of proper materials, and the removal and proper re-execution of any work executed with materials and workmanship not in accordance with the drawings and specifications or instructions, and the CONTRACTOR shall forthwith carry out such order, the OWNER shall have the power to employ and pay other persons to carry out the same, and all expenses consequent thereon, or incidental thereto, as certified by the or OWNER shall be borne by the CONTRACTOR, or may be deducted by the OWNER from any money due, or that may become due to the CONTRACTOR.

8.21 Defects after virtual completion



Any defect, shrinkage, settlement or other faults which may appear within the “Defects Liability Period” stated in the Appendix hereto or , if none stated, then within twelve months after the virtual completion of the works, arising in the opinion of the or OWNER from materials or workmanship not in accordance with the contract, shall upon the directions in writing of OWNER and within such reasonable times as shall be specified therein, be amended and made good by the CONTRACTOR, at his own cost and in case of default the OWNER may employ and pay other persons to amend and make good such defects, shrinkage, settlements or other faults and all damages, loss and expenses consequent thereon or incidental thereto shall be made good and borne by the CONTRACTOR and such damage, loss, expenses shall be recoverable from him by the OWNER or may be deducted by the OWNER , upon the ’s Certificate in writing, from any money due or may become due to the CONTRACTOR, or the OWNER may in lieu of such amending and making good by the CONTRACTOR deduct from any money due to the CONTRACTOR, a sum, to be determined by the or OWNER equivalent to the cost of amending such work and in the event of the amount retained thereof being insufficient, recover the balance from the CONTRACTOR, together with any expenses the OWNER may have incurred in connection therewith. Should any defective work have been done or material supplied by any sub-CONTRACTOR employed on the works who has been nominated or approved by the OWNER thereof, the CONTRACTOR shall be liable to make good in the same manner as if such work or material had been done or supplied by the CONTRACTOR and been subject to the provisions of contract. The CONTRACTOR shall remain liable under the provisions of this contract Clause notwithstanding the signing of any certificate or the passing of any accounts, by the OWNER.

8.22 Certificate of Virtual Completion and Defects Liability Period

The works shall not be considered as completed until the OWNER has certified in writing that they have been virtually completed. The Defects Liability Period shall commence from the date of issue of such certificate.

8.23 Nominated SUB -CONTRACTORS

- (a) All Specialists, Merchants, Tradesman and other executing any work of supplying and fixing any goods for which prime cost prices or provisional sums are included in the Schedule of Quantities and/or Specifications who may be nominated or selected by the are hereby declared to be SUB-CONTRACTORS employed by the CONTRACTOR and are herein referred to as nominated SUB -CONTRACTORS.
- (b) No nominated SUB -CONTRACTOR shall be employed by the CONTRACTOR



in connection with this work unless he complies with the following conditions:-

- (i) That the nominated SUB -CONTRACTOR shall indemnify the CONTRACTOR against the same obligation in respect of the Sub-Contract as the CONTRACTOR is under in respect of this contract.
- (ii) That the nominated SUB -CONTRACTOR shall indemnify the CONTRACTOR against claims in respect of any negligence by the SUB -CONTRACTOR, his personnel or engineer or any misuse by him or them of any scaffolding or other plant, the property of the CONTRACTOR or under any Workmen's Compensation Act in force.
- (iii) Payment shall be made to the nominated SUB -CONTRACTOR within fourteen days of his receipt of the OWNER's Certificate provided that before any certificate is issued the CONTRACTOR shall upon request furnish to the OWNER proof that all nominated SUB -CONTRACTOR's accounts included in previous Certificates have been duly discharged, the default whereof the OWNER may pay the same upon a Certificate of the and deduct the amount thereof from any sum due to the CONTRACTOR. The exercise of this power shall not create brevity of contract as between OWNER and SUB -CONTRACTOR.

8.24 Other persons employed by OWNER

The OWNER reserves the right to use premises and any portions of the site for the execution of any work not included in this Contract which it may desire to have carried out by other persons and the CONTRACTOR shall allow all reasonable facilities for the execution of such work but shall not be required to provide any plant or material for the execution of such work except by special arrangement with the OWNER. Such work shall be carried out in such manner as not to impede the progress of the works included in the Contract and the CONTRACTOR shall not be responsible for any damage or delay which may happen to or occasioned by such work.

8.25 Insurance in respect of damages to persons and property

- (a) The CONTRACTOR shall be responsible for all injury or damage to persons, animals or things and for all damage to property which may arise from any factor omission on the part of the CONTRACTOR or any SUB- CONTRACTOR or any nominated SUB -CONTRACTOR or any of their employees. The liability under this clause shall cover also inter-alia any damage to



structures, whether immediately adjacent to the works or otherwise, any damage to roads, streets, footpaths, bridges as well as damage caused to the building and other structures and works forming the subject matter of this contract. The CONTRACTOR shall also be responsible for any damage caused to the buildings and other structures and works forming the subject matter of this contract due to rain, wind, frost or other inclemency of weather. The CONTRACTOR shall indemnify and keep indemnified the OWNER and hold him harmless in respect of all and any loss and expenses arising from any such injury or damage to persons or property as aforesaid and also against any claim made in respect of injury or damage, whether under any statute or otherwise and also in respect of any award or compensation or damage consequent upon such claims. The CONTRACTOR shall, at his own expense, effect and maintain till issue of the virtual completion certificate under this contract, with an insurance company approved by the OWNER , an All Risks Policy for Insurance for the full amount of the contract including earth quake risk in the joint names of the OWNER and the CONTRACTOR (the name of the former being placed first in the policy) against all risks as per the standard all risk policy for CONTRACTORS and deposit such policy or policies with the OWNER before commencing the works.

- (b) The CONTRACTOR shall reinstate all damage of every sort mentioned in this clause so as to do delivery of the whole of the works complete and perfect in every respect and so as to make good or otherwise satisfy all claims for damage to property or third parties.
- (c) The CONTRACTOR shall also indemnify and keep indemnified the OWNER against all claims which may be made against the OWNER by any person in respect of anything which may arise in respect of the works or in consequence thereof and shall at his own expense, effect and maintain until the virtual completion of the contract, with an Insurance Company approved by the OWNER a policy of Insurance in the joint names of the OWNER and the CONTRACTOR (name of the former being placed first in the policy) against such risks and deposit such policy or policies before commencement of the works.
- (d) The minimum limit of the coverage under the policy shall be Rs.1 Lakhs per person for any one accident or occurrence and Rs.3 Lakhs in respect of damage to property for any one accident or occurrence. The CONTRACTOR shall also indemnify the OWNER against all claims which may be made upon



the OWNER , whether under the Workmen's Compensation Act or any other statute in force, during the currency of this contract or at Common Law in respect of any employee of the CONTRACTOR or SUB -CONTRACTOR and shall be at his own expense, effect and maintain until the Virtual Completion of the Contract with an Insurance Company approved by the OWNER a policy of Insurance against such risks and deposit such policy or policies with the OWNER from time to time during the currency of this contract.

- (e) In default of the CONTRACTOR insuring as provided above, the OWNER may so insure and may deduct the premiums paid from any money due or which may become due to the CONTRACTOR.
- (f) The CONTRACTOR shall be responsible for any liability which may not be covered by the insurance policies referred to above and also for all other damages to any person, animal or defective carrying out of this contract, whatever, may be the reasons due to which the damage shall have been caused.
- (g) The CONTRACTOR shall also indemnify and keep indemnified the OWNER against all and any costs, charges or expenses arising out of any claim or proceedings relating to the works and also in respect of any award of damage or compensation arising there from.
- (h) Without prejudice to the other rights of the OWNER against CONTRACTORS in respect of such default, the OWNER shall be entitled to deduct from any sums payable to the CONTRACTOR the amount of any damages, compensation costs, charges and other expenses paid by the OWNER and which are payable by the CONTRACTOR under this clause.
- (i) The CONTRACTOR shall upon settlement by the insurer of any claim made against the insurer pursuant to a policy taken under this clause, proceed with due diligence to rebuild or repair the works destroyed or damaged. In this event all the money received from the insurer in respect of such damage shall be paid to the CONTRACTOR and the CONTRACTOR shall not be entitled to any further payment in respect of the expenditure incurred for rebuilding or repairing of the materials or goods destroyed or damaged.
- (j) The CONTRACTOR, in case of re-building or reinstatement after damage shall be entitled to such extension of time for completion as the OWNER may deem fit, but shall, however, not be entitled to reimbursement by the OWNER of any shortfall or deficiency in the amount finally paid by the insurer in settlement of any claim arising as set out herein.



(k) Without prejudice to his liability under this clause, the CONTRACTOR shall also cause all nominated SUB -CONTRACTORS to effect, for their respective portions of the works similar policies of insurance in accordance with the provisions of this clause and shall produce or cause to produce to the OWNER such policies. The CONTRACTOR shall not permit a nominated SUB -CONTRACTOR to commence work at the site unless said insurance policies are submitted. In the event of failure, of the SUB -CONTRACTOR to take out such policy or policies of insurance before commencing the works at the site, the CONTRACTOR shall be responsible for any claim or damage attributable to the said SUB -CONTRACTOR.

8.26 Date of commencement and completion

The CONTRACTOR shall be allowed admittance to the site on the "Date of Commencement" stated in the Appendix hereto, or such later date as may be specified by the or OWNER and he shall thereupon and forthwith begin the work and shall regularly proceed with and complete the same (except such painting or other decorative work as the or OWNER may desire to delay) on or before the "Date of Completion" stated in the Appendix subject nevertheless to the provision for extension of time hereinafter contained.

8.27 Damage for non-completion

If the CONTRACTOR fails to complete the works by the date stated in the Appendix or within any extended time thereof and the OWNER certifies in writing that in his opinion the same ought reasonably to have been completed the CONTRACTOR shall pay the OWNER the sum, named in the Appendix as agreed "**Liquidated Damages**" for the period during which the said works so remain incomplete **@ 0.5% of the delayed value of the delayed work shall be levied per week delay or part thereof, subject to a maximum of 10% of total value of works completed / final bill value** and the OWNER may deduct such damages from any money due from the CONTRACTOR.

8.28 Delay and Extension of Time

If in the opinion of the OWNER, the works be delayed

- (a) by force majeure or
- (b) by reason of any exceptionally inclement weather or
- (c) by reason of proceedings taken or threatened by or dispute with adjoining or neighbouring OWNER S or public authorities arising otherwise than



through the CONTRACTOR's own fault or

- (d) by the works or delays of other CONTRACTORS or Tradesmen engaged or nominated by the OWNER or the and not referred to in the Schedule of Quantities and/or Specification or
- (e) by reason of 's instruction hereof or
- (f) by reason of civil commotion, local combination of workmen or strike or lockout affecting any of the building trades or
- (g) in consequence of the CONTRACTOR not having received in due time necessary instructions from the or OWNER for which he shall have specifically applied in writing or
- (h) from other causes which the or OWNER may certify as beyond the control of CONTRACTOR or
- (i) in the event, the value of the work exceed the value of the Priced Schedule of Quantities owing to variation,

The OWNER may with previous approval in writing of the OWNER, make a fair and reasonable extension of time for completion of the contract works. In case of such strike or lock-out, the CONTRACTOR shall immediately give written notice thereof to the or OWNER but the CONTRACTOR shall nevertheless constantly use his endeavours to prevent delay and shall do all that may reasonably be required to the satisfaction of the or OWNER to proceed with work.

If the CONTRACTOR needs an extension of time for the completion of the work or if the completion of work gets delayed for any reason beyond the due date of completion stipulated in the contract, the CONTRACTOR shall apply to the OWNER for extension of time in writing at least 7 days before the expiry of the scheduled time and while applying for extension of time CONTRACTOR shall furnish the reasons in detail and his justification, if any, for delays. Only that period of extension of time as granted by the OWNER (on receipt of the application from the CONTRACTOR or even in absence of any such application) will qualify for exemption of imposition of liquidated damages. For the balance period in excess of original stipulated period and authorized extension of time granted by the OWNER, the provision of liquidated damages as stated in tender will become applicable.

Further the contract shall remain in force even for the period beyond the due date of completion irrespective whether the CONTRACTOR has applied or not, for the grant of extension of time for completion unless the OWNER decides to terminate the contract.



The delay for completion of work for any reason will not entail any right to the CONTRACTOR to claim any revision of rates or any extra compensation for any reason.

8.29 Failure by CONTRACTOR to comply with 's Instructions

If the CONTRACTOR after receipt of written notice from the requiring compliance within ten days, fails to comply with such further drawings and instructions, the OWNER may employ and pay other persons to execute any such work whatsoever, that may be necessary to give effect thereto, and all costs incurred in connection therewith shall be recoverable from the CONTRACTOR by the OWNER on the Certificate as a debit or may be deducted by him from any money due to the CONTRACTOR.

8.30 Termination of Contract by the OWNER

- (a) If the CONTRACTOR being an individual or a firm commits any "Act of insolvency", or shall be adjudged an Insolvent or being an Incorporated Company shall have an order for compulsory winding up made against it or pass an effective resolution for winding up voluntarily or subject to the supervision of the Court and the Official Assignee or the Liquidator in such acts of insolvency or winding up, as the case may be, shall be unable within seven days after notice to him requiring him to do so, to show to the reasonable satisfaction of the or OWNER that he is able to carry out and fulfil the contract and to give security therefore, if so required by the or OWNER ; OR
- (b) If the CONTRACTOR (when and individual, firm or Incorporated Company) shall suffer execution or other process of Court attaching property to be issued against the CONTRACTOR ;OR
- (c) shall suffer any payment under this Contract to be attached by or on behalf of any of the creditors or the CONTRACTOR ;OR
- (d) shall assign or sublet this Contract without the consent in writing of the OWNER first hand and obtained ;OR
- (e) shall charge-off encumber this Contract or any payments due or which may become due to the CONTRACTOR hereunder ;OR
- (f) if the shall clarify in writing to the OWNER that the CONTRACTOR,
 - (i) has abandoned the Contract ;or



- (ii) has failed to commence the works, or has without any lawful excuse under these Conditions suspended the progress of the works for fourteen days after receiving from the or OWNER notice to proceed ;or
- (iii) has failed to proceed with the works with such due diligence and failed to make such due progress as would enable the works to be completed within the time agreed upon ; or
- (iv) has failed to remove materials from the site or to pull down and replace work for seven days after receiving from the or OWNER written notice that the said Materials or work were condemned and rejected by the or OWNER under these conditions; or
- (v) has neglected or failed persistently to observe and perform all or any of the acts, matters of things by this contract to be observed and performed by the CONTRACTOR for seven days after written notice, shall have been given to the CONTRACTOR requiring the CONTRACTOR to observe or perform the same.

Then and in any of the said events the OWNER may, notwithstanding any previous waiver, after giving seven days' notice in writing to the CONTRACTOR, determine the Contract, but without thereby affecting the powers of the OWNER or the obligations and liabilities of the CONTRACTOR, the whole of which shall continue in force as fully as if the Contract had not been so determined, and as if the work subsequently executed had been executed by or on behalf of the CONTRACTOR. And further, the OWNER by his Engineers may enter upon and take possession of the works and all plants, tools, scaffoldings, sheds, machinery steam and other power utensils and materials lying upon the premises or the adjoining lands or roads, and use the same as his own property or may employ the same by means of his own personnel in carrying on and completing the works or by employing any other contractor or other person or persons to complete the works, and the CONTRACTOR shall not in any way interrupt or do any act, matter or thing to prevent or hinder such other contractor or other person or persons employed for completing and finishing or using the materials and plant for the works. When the works shall be completed or as soon thereafter as convenient the or OWNER shall give a notice in writing to the CONTRACTOR to remove his surplus materials and plant, and should the CONTRACTOR fail to do so within a period of fourteen days after receipt of thereof by him, the OWNER may sell the same by public auction, and give credit to the



CONTRACTOR for the net amount realised. The shall thereafter ascertain and certify in writing under his hand what (if anything) shall be due or payable to or by the OWNER and expense or loss which the OWNER shall have been put to in procuring the works to be completed and the amount, if any, owing to the CONTRACTOR and the amount which shall be so certified shall thereupon be paid by the OWNER to the CONTRACTOR or by the CONTRACTOR to the OWNER , as the case may be, and the Certificate of the shall be final and conclusive between the parties.

8.31 Termination of Contracts by CONTRACTOR

- (a) If the payment of the amount payable by the OWNER under Certificate of the OWNER shall be in arrears and unpaid for thirty days after notice in writing requiring payment of the amount as aforesaid shall have been given by the CONTRACTOR to the OWNER , or if the OWNER interferes with or obstructs the issue of any such Certificate, or if the OWNER shall repudiate the Contract, or if the works be stopped for three months under the order of the or the OWNER or by any injunction or other order of any court of Law, then and in any of the cases the CONTRACTOR shall be at liberty to determine the Contract by notice in writing to the OWNER , through the and he shall be entitled to recover from the OWNER , payment for all works executed and for any loss he may sustain upon any plant or materials supplied or purchased or prepared for the purpose of the Contract.
- (b) In arriving at the amount of such payment the net rates contained in the CONTRACTOR's original tender shall be followed or where the same may not apply, valuation shall be made in accordance with Clause 8.18 hereof.

8.32 Certificate of payments

- (a) The CONTRACTOR shall be paid by the OWNER from time to time by instalments under Interim Certificates to be issued by the to the CONTRACTOR on account of the works executed when in the opinion of the , work to the approximate value named in the Appendix as "Value of Work for Interim Certificates" (or less at the reasonable discretion of the or OWNER) has been executed in accordance with this contract, subject, The OWNER may in his discretion include the Interim Certificate such amount as he may consider proper on account of materials delivered upon the site by the CONTRACTOR for use in the works. And when the works have been virtually completed and the OWNER shall have certified in writing that they have been completed, the CONTRACTOR shall be paid by the OWNER in



accordance with the Certificate to be issued by the OWNER the sum of money named in the Appendix as "Instalment after Virtual Completion". The issue by the of any Certificate during the progress of the works or after their completion shall not relieve the CONTRACTOR from his liability nor relieve the CONTRACTOR of his liability in case of fraud, dishonesty or fraudulent concealment relating to the works or materials or to any matter dealt with in the certificate, and in case of all defect and insufficiencies in the works or materials which a reasonable examination would not have disclosed. No certificate of the shall of itself be conclusive evidence that any works or materials to which it relates are in accordance with the Contract neither will the CONTRACTOR have a claim for any amounts which the might have certified in any interim bill and paid by the OWNER and which might subsequently be discovered as not payable and in this respect the OWNER's decision shall be final and binding.

- (b) The OWNER shall have power to withhold any certificate if the works or any parts thereof are not being carried out to his satisfaction.
- (c) The OWNER may by any Certificate make any correction in any previous certificate which shall have been issued by him.
- (d) No payment shall be made to the CONTRACTOR if the CONTRACTOR fails to insure the works and keep them insured till the issue of the Virtual Completion Certificate.
- (e) Payments upon Certificate shall be made within the periods named in the Appendix as "Period for honour of Certificates" after such certificates has been delivered to the OWNER.

8.33 Matter to be finally determined by or OWNER

The decision, opinion, direction, certificate of payment with respect of to all or any of the matters hereof (which matters are herein referred to as excepted matters) shall be final and conclusive and binding on the parties hereto and shall be without appeal. Any other decision, opinion, direction. Certificate of valuation of the or OWNER or any refusal of the or OWNER to give any of the same, shall be subject to the right of Arbitration and review thereof in the same way in all respect (including the provisions as to opening the reference) as if it were a decision of the or OWNER .

8.34 Arbitration



Any dispute or difference whatsoever arising between the Parties out of or relating to the construction, meaning, scope operation or effect of this Agreement or the validity or the breach thereof shall be settled by arbitration in accordance with the Arbitration and Conciliation Act, 1996 and under the Rules of Arbitration of the Indian Council of Arbitration and the award made in pursuance thereof shall be binding on the Parties. The Arbitral Tribunal shall consist of three Arbitrators. The venue of the Arbitration shall be Bangalore / Mysore and it shall be conducted in English language.

If any dispute arises after the issue of LOI /Work order and during the execution of the project which is not resolved within 30 days of their arising, they shall be referred to a sole arbitrator to be appointed by the Managing Director of BNPMIPL. The governing law in this regard will be The Arbitration and Conciliation Act, 1996 of India. The venue of the Arbitration will be Mysuru. Further, disputes if any that may arise at any point of time shall be subject to Mysuru jurisdiction only. However the right of giving the list of arbitrators for selection of sole arbitrator by the parties is exclusively kept reserved by BNPMIPL whose decision shall be final and binding on the parties. Right of Technical Scrutiny of Final Bill

8.35 OWNER entitled to recover compensations paid to workman

If, for any reason, the OWNER is obliged by virtue of the provisions of the Workmen's Compensation Act, 1923, or any statutory modification or re-enactment thereof to pay compensation to a workman employed by the CONTRACTOR in execution of the works, the OWNER shall be entitled to recover from the CONTRACTOR the amount of compensation so paid and without prejudice to the rights of the OWNER under the said Act. The OWNER shall be at liberty to recover such amount or any part thereof by deducting it from the security deposit or from any sum due by the OWNER to the CONTRACTOR under this Contract or otherwise. The OWNER shall not be bound to contest any claim made against it under the said Act, except on the written request of the CONTRACTOR and upon his giving to the OWNER full security to the satisfaction of the OWNER for all costs for which the OWNER might become liable in consequence of contesting such claim.

8.36 Abandonment of works

If at any time after the acceptance of the tender, the OWNER shall for any reasons whatsoever not require the whole or any part of the work to be carried out, the OWNER shall before commencement of such part of the work give notice in writing



to the CONTRACTOR who shall have no claim to any payment of compensation or otherwise whatsoever on account of any profit or advantage which he might have derived from the execution of the whole works.

8.37 Return of surplus materials

Notwithstanding anything to the contrary contained in any or all the clause of this Contract, where any material for the execution of the Contract is procured with the assistance of the OWNER by purchases made under orders or permits or licenses issued by Government, the CONTRACTOR shall hold the said Materials economically and solely for the purpose of the Contract and not dispose them without the prior written permission of the OWNER and return it to the OWNER , if required by the OWNER , at the price to be determined by the having due regard to the condition of the materials, the price to be determined not to exceed the purchase price thereof inclusive of sales tax, service tax, octroi and other such levies paid by CONTRACTOR in respect thereof. In the event of breach of the aforesaid condition, the CONTRACTOR shall, in addition to being liable to action for contravention of the terms of licenses or permit and or criminal breach of trust, be liable to OWNER for all moneys, advantages or profits resulting or which in the usual course would have resulted by reason of such breach.

8.38 Right of OWNER to terminate contract in the event of death of CONTRACTOR if individual, without prejudice to any of the rights or remedies under this contract, if the CONTRACTOR, being an individual, dies, the OWNER shall have the option of termination of the contract without incurring any liability for such termination.

8.39 Marginal Notes

The Marginal Notes and in the catch liens hereto are meant only for convenience of reference and shall not in any way be taken into account in the interpretation of these presents. The CONTRACTOR will have to carry out and complete the said work in every respect in accordance with this contract.

8.40 Confidentiality and Assurance

CONTRACTOR hereby assures that the entire information obtained during the executing of contract, shall be kept confidential and the CONTRACTOR and their personnel shall not divulge, convey, reveal, communicate or disclose to any other person / party / entity in whole or in part any information of confidential nature that may come to their knowledge without the written consent of the OWNER . CONTRACTOR hereby undertakes to maintain the secrecy, exclusivity and



confidentiality of the high security currency printing environment of OWNER. However, Confidential Information shall not include any information which:

- (a) is developed by the CONTRACTOR independently of OWNER
- (b) is contained in a printed publication prior to the date of this Agreement
- (c) Is or becomes publicly known through no wrongful act or failure to act on the part of CONTRACTOR.
- (d) Is known by CONTRACTOR without any proprietary restrictions at the time of receipt of such Information from OWNER or becomes known to CONTRACTOR without proprietary restrictions from a source other than OWNER.

8.41 Heading Clause

The headings given to the sections, sub-sections, chapters, paragraphs and other sub-divisions herein are inserted only for convenience and are in no way to be construed as a part of this indenture of agreement or as a limitation of the scope of the particular sections, sub-sections, chapters, paragraphs and other sub-divisions to which the headings refer.

8.42 Continuing Obligation :Survival

Notwithstanding anything to contrary contained in this indenture or any related document, termination or expiration of this agreement for any reason shall not relieve either party of its obligation with respect to the confidentiality and assurance information, shall not relieve either party from any obligation that expressly or by implication survives termination, and termination, expiration or cancellation of these terms.



Appendix Hereinbefore referred to; Reference to clauses in Conditions Herein before Referred To

1.	Description of work	Water proofing works and construction of watch tower (1 no.) at BNPM premises, Mysore.
2.	Defects Liability Period	12 Months after date of completion of work (virtual completion certificate)
3.	Earnest Money Deposit	₹ 20,000/- (Rupees Twenty Thousand only).
4.	Period of Final Measurement	30 days from the date of virtual completion
5.	Date of Commencement of Work	Within 10 days of issue of LOI/WO
6.	Date of Completion	3 months from date of commencement of work
7.	Liquidated Damage	@ 0.5% of the delayed value of the delayed work shall be levied per week delay or part thereof, subject to a maximum of 10% of total value of works completed / final bill value.
8.	Terms & Modes of payment	100% for certified bill amount shall be paid. All payment made towards RA bills shall be considered as advance against the final payment.
9.	Value of works for interim certified running account payment	Rs. 5 Lakhs (100% for certified running account bill amount shall be paid)
10.	Security Deposit	Security deposit shall be submitted in the form of BG for the 10% of contract value which shall be released after completion of DLP and 2 months claim period. BG shall be submitted within 21 days after the issue of LOI/WO.
11.	Period of honouring certificates of payment	20 days for running account bills & 30 days for final bills

OWNER

CONTRACTOR



9. SPECIAL CONDITIONS OF CONTRACT

9.1 GENERAL

- 9.1.1 Special conditions of Contract shall be read in conjunction with the General Conditions of Contract, specifications of work, drawings and any other documents forming part of this contract wherever the context so requires.
- 9.1.2 Notwithstanding the sub-divisions of the document into these separate sections and volumes every part of each shall be deemed to be supplementary to and complementary of every other part and shall be read with and into the contract so far as it may be practicable to do so.
- 9.1.3 Where any portion of the Special Conditions of Contract is repugnant to or at variance with any provisions of the General Conditions of Contract then unless a different intention appears, the provision(s) of the Special Conditions shall be deemed to override the provision(s) of the General conditions of Contract only of the extent that such repugnance or variations cannot and shall be to the extent that such repugnance or variance cannot be reconciled with the General Conditions of Contract.
- 9.1.4 Wherever it is stated anywhere in this tender document that such and such supply is to be effected or such and such work is to be carried out, it shall be understood that the same shall be effected / carried out by the CONTRACTOR at his own cost, unless a different intention is specifically stated.
- 9.1.5 Unless specified in Engineering Specifications, the materials and workmanship shall satisfy the relevant CPWD specifications, Specifications of Indian Standards, the job specifications contained herein and codes referred to. Where the Engineering Specification stipulate requirements in addition to those contained in the standard codes and specification, these additional; requirements shall also be satisfied. In the absence of any standard/ specifications covering any part of the work covered in this Tender, the specifications to be followed shall be the latest CPWD Specification applicable in this region and instructions/ directions of OWNER will be binding to the CONTRACTOR.
- 9.1.6 The items given in Schedule of Rates shall be read in conjunction with materials and job specifications and in case of any irreconcilable conflict between them, the provisions in the item under Schedule of Rates will override the corresponding provisions only of the material and job specifications, which cannot be reconciled. In



such cases, the decisions of the OWNER shall be final and binding on the CONTRACTOR.

9.1.7 In case of contradiction between General Conditions of Contract, Special Conditions of Contract, Technical specification, Drawings, Schedule of Rates, the following shall prevail in order of precedence:

- (a) FAX of Intent, detailed letter of intent along with statement and agreed variations and its enclosures.
- (b) Schedule of Price
- (c) Special Conditions of Contracts.
- (d) Technical Specifications
- (e) Drawings
- (f) General Conditions of contracts
- (g) Technical/ Material specifications.

9.2 SITE PARTICULARS

The intending Tenderer shall be deemed to have visited the site and familiarized themselves thoroughly with the site conditions before submitting the tender. Non familiarity with the site conditions will not be considered as reason either for extra claims or for not carrying out the work in strict conformity with the drawings and specifications. For site visit, the intending tenderer may contact the OWNER, and may inspect the geo technical data about the site which will be only for the information purpose.

9.3 INTERRUPTION OF SUPPLY OF WATER/ POWER

9.3.1 The CONTRACTOR shall not be entitled to any compensation for delay caused by interruptions or failure of water/power supply. In Such case, **the CONTRACTOR shall arrange water and Power for construction works at his own cost.**

9.3.2 All electrical works shall be carried out under the supervision of a licensed Electrician. The electrical connections carried out by the CONTRACTOR shall meet the statutory requirements. Changes, if any, as incorporated in the statutory rules and regulations from time to time shall be applicable to the electrical connection done by the CONTRACTOR. The following conditions shall also be fulfilled;



- (a) All the equipment's/ distribution boxes should have double earthing from the nearest earth pits or from the board earth bus.
- (b) All electrical connections have to be done by a competent licensed Electrician with valid license (HT/LT) and to the satisfaction of the OWNER.
- (c) During working hours (including over time) one licensed competent Electrician shall be available at site to attend to the normal jobs/ emergency jobs.
- (d) All switch boards/ welding machines shall be kept inside covered sheds to protect them from rain. No inflammable materials shall be used for constructing the covered sheds.
- (e) All electrical equipment's shall be switched off after the job, every day by the CONTRACTOR's authorized Electrician.
- (f) Only metallic distribution boxes with double earthing shall be used at the site. Wooden boxes shall not be allowed.
- (g) Supply for lighting/ grinding shall be taken only using 3 pin plug/ socket connectors with inter locking arrangements. Two pin plugs shall not be allowed.
- (h) CONTRACTOR shall submit in time the required forms like schemes, completion report etc., as specified by OWNER.
- (i) No looping of Electrical supply is allowed.
- (j) For all three phase supplies, only armoured aluminium cables of suitable sizes or flexible copper cables of 4x6 sq. mm and above shall be allowed.
- (k) No loose wiring/unauthorised connection is allowed

9.4 TIME SCHEDULE

- 9.4.1 Time is the essence of this contract and the entire work as per this contract shall be completed within a period of **03 (Three) months** from the date of issue of Letter of Intent (LOI) /award of contract.
- 9.4.2 The site work shall commence immediately from the date of Letter of Intent issued for the job.
- 9.4.3 Weekly construction programme will be drawn up by the OWNER jointly with the CONTRACTOR based on availability of materials, work fronts and the joint



programme of execution as referred to above. The CONTRACTOR shall scrupulously adhere to the Targets/ Programme by deploying adequate personnel, construction equipment, tools and tackles and also by timely supply or required materials coming within his/her scope of supply as per Contract. In all matters concerning the extent of targets set out in the monthly/ weekly programme and the degree of achievement, the decision of OWNER will be final and binding on the CONTRACTOR.

9.5 SUPERVISION OF WORK

9.5.1 The CONTRACTOR is bound to deploy sufficient number of experienced engineers and supervisors (Technical & General) for the execution of the work.

9.5.2 Sufficient numbers of qualified and experienced graduate civil engineers/ or civil Diploma holder in the relevant field of work awarded shall be made available at site from commencement till completion of the job and settlement of final bill. The number of Diploma holders/ graduates engineer will be decided by the OWNER based on the volume and nature of work. The decision of OWNER will be binding and final in this regard.

9.6 UNDERGROUND PIPELINES/ CABLES/ ELECTRIC TOWERS

Underground pipelines and its coverings/ cables/ electric towers should not be damaged or dislocated while doing earthwork excavation, P.C.C., R.C.C. etc. repairing charges and loss incurred for the damages will be deducted from running account bills of CONTRACTOR. CONTRACTOR has to provide temporary supports, if required, to underground pipelines/ cables/ towers without any extra rates. Works below underground pipelines/ cables shall be done with the available gap between pipelines/ cables. Works near electric towers are to be carried out safely to avoid any accidents due to electric shock.

9.7 DAILY LABOUR REPORT AND PROGRESS REPORT

The CONTRACTOR should submit daily labour report indicating the details of the contract labour engaged for the day to the OWNER. Further, the CONTRACTOR should submit weekly progress report showing the actual quantum of work done at site against the programmed quantum, after finalizations of the schedule of the work in consultation with the or OWNER .

9.8 SUPPLY OF MATERIALS



- 9.8.1 The OWNER shall not supply any building material. The CONTRACTOR is required to procure all the material necessary for completion of all the construction activities under the scope of work.
- 9.8.2 CONTRACTOR shall at his cost make his own arrangements for the storage of their construction material at the work site as specified / directed.
- 9.8.3 Tests on Cement, steel and all other building materials shall be conducted as per the periodicity indicated in the respective IS Codes and Test Certificate shall be produced to the OWNER from time to time as required by the relevant Codes.
- 9.8.4 Test certificates of random samples of materials and construction work shall be furnished as directed by OWNER S from time to time.
- 9.9 It may become necessary to substitute reinforcement bars/steel sections as the diameters/sections shown on drawings are not available. All such substitutions shall be ascertained and listed by CONTRACTOR and shall obtain OWNER's approval in writing to all such substitutions, prior to utilizing them for the work. No extra claim shall be allowed in this account.
- 9.10 STORAGE OF MATERIALS AND CONSTRUCTIONS OF SITE SHED
- (a) CONTRACTOR has to find a suitable place for the storage of all types of materials, working place and storing place for steel, cement, structural steel and for site. The same may be got approved through to meet the safety requirements. Rate shall include all leads and lift of materials to the site of construction. No claim will be entertained for any extra cost on this account. OWNER will not be responsible for any theft or damage. CONTRACTOR has to make his own security arrangements to protect the material from theft at his own cost.
 - (b) If required, CONTRACTOR may construct a Cement Godown at his own cost for storing the cement after obtaining the permission form the OWNER.
 - (c) Any excess materials/ construction equipment, tools etc. owned by the CONTRACTOR shall be removed periodically and the site should be left in spic and span condition after the completion of work.
- 9.11 INCOME TAX
- (a) Tenderer are required to quote their Permanent Account Number (PAN)/GST in their Tenders or other relevant documents/ invoices.



(b) Income Tax at the prevailing rate shall be deducted (TDS) from the CONTRACTOR's bills as per Indian Income Tax Act. A TDS certificate shall be issued by the OWNER to this effect.

9.12 CONSTRUCTION EQUIPMENT AND SITE ORGANISATIONS

9.12.1 Construction Equipment:

The CONTRACTOR shall without prejudice to his overall responsibility to execute and complete the work as per specifications and time schedule, progressively deploy adequate equipment's and tools and tackles and augment the same as decided by the OWNER depending on the exigencies of the work so as to suit the construction schedule. No construction equipment shall be supplied by the OWNER.

9.12.2 Site Organisations:

Subject to the provisions in the tender document and without prejudice to CONTRACTOR's liabilities and responsibilities to provide adequate and skilled personnel on the work, CONTRACTOR shall deploy site organization and augment the same as decided by the or OWNER depending on the exigencies of work.

9.12.3 The tenderer shall submit the details of minimum site organizations proposed by him, along with the tender document.-Not Applicable.

9.13 CO-ORDINATION WITH OTHER AGENCIES

Work shall be carried out in such a manner that the work of other agencies operating at the site is not hampered due to any action of the CONTRACTOR. Proper co-ordination with other agencies will be CONTRACTOR's responsibility. In case of any dispute, the decision of OWNER shall be final and binding on the CONTRACTOR.

9.14 ORDER OF WORKS

OWNER reserves the right to fix up priorities which will be conveyed by and the CONTRACTOR shall plan and execute work accordingly.

9.15 FRONTS FOR WORKS WHERE OTHER AGENCIES ARE INVOLVED

The work involved under this contract includes such works as have to be taken up and completed after other agencies on the job have completed their jobs. The CONTRACTOR will be required and bound to take up and complete such works as and when the fronts are available for the same and no claim of any sort whatsoever



shall be admissible to the CONTRACTOR on this account. Only extension of time limit shall be admissible, if the availabilities of work fronts to the CONTRACTOR are delayed due to any reasons not attributable to the CONTRACTOR.

9.16 QUALITY ASSURANCE & QUALITY CONTROL PROGRAMME

- (a) The CONTRACTOR has to ensure the Quality Assurance and Quality work. **The work shall be carried out as per relevant IS standards and all relevant IS code requirements and at the discretion of BNPM.**
- (b) In case CONTRACTOR fails to follow the instruction of OWNER as per above, next payment due to him shall not be released unless until he complies with the instructions to the full satisfaction of OWNER.
- (c) Quality Assurance System Plans/procedures of the CONTRACTOR shall be furnished in the form of a QA manual. This document should cover details of the personnel responsible for the Quality Assurance plans or procedures to be followed for quality control in respect of Procurement, Supply, Installation and Commissioning including laboratories for testing materials. The quality assurance system should indicate organizational approach for quality control and quality assurance of the construction activities, at all stages of work at site as well as at manufacturer's works and dispatch of materials.

9.17 CORRECTIONS

9.17.1 All corrections and alterations in the entries of tender papers shall be signed in full by the tenderer with date. No erasures or over writing are permissible. If any discrepancies are found between the values given in words and figures of the rates quoted, the following procedures shall be followed:

- (a) When there is a difference between the values of rate quoted in figures and words, the value which corresponds to the amount worked out by the tenderer shall be taken as correct.
- (b) When the values of rate quoted by the tenderer in figures and words tally, but the amount is incorrect, the rate quoted by the tenderer shall be taken as correct.
- (c) When it is not possible to ascertain the correct rate as prescribed above, the rates in words shall be deemed correct.

9.18 RESPONSIBILITY OF CONTRACTOR



- (a) The CONTRACTOR shall be entirely responsible for executing the work covered under this Tender document in a safe, efficient and expeditious manner as per the time schedule, specifications, drawings and construction aids such as piling equipments, JCB/ poclain, mixer machine/ batching plant, arc welding sets, gas cutting sets, cranes, chain pulley blocks, transportation equipments, tools and tackles as well as teasing appliances such as test pumps, air compressors etc. and the necessary supervisory personnel, skilled, semi-skilled and unskilled labour shall be provided by the CONTRACTOR to achieve the monthly/weekly targets and the overall time schedule.
- (b) The CONTRACTOR shall ensure that local labour, unskilled as well as skilled to the extent possible and available from local resources, are preferentially employed on the work with special priority being given to the persons. For any infringement of this provisions, the OWNER shall be at liberty to rescind the contract without any liability to pay any compensation whatsoever to the CONTRACTOR.
- (c) It shall be entirely the CONTRACTOR's responsibility to provide, operate and maintain all necessary construction equipments, scaffoldings and safety gadgets, cranes and other lifting tackles, tools and appliances to perform the work in a safe and efficient manner and complete all the jobs as per time schedules.
- (d) Preparing approaches and working area for the movement and operation of the cranes, vehicles & levelling the areas for assembly and erection shall also be the responsibility of the CONTRACTOR. The CONTRACTOR shall acquaint himself with access availability, facilities such as railway siding, local labour etc. to provide suitable allowances in his quotation. The CONTRACTOR may have to build temporary access roads to aid his own work which shall also be taken care while quoting for the work. The CONTRACTOR has to dismantle these temporary approach roads after completion of job without any extra cost.
- (e) The procurement and supply in sequence and at the appropriate time of all materials and consumables shall be entirely the CONTRACTOR's responsibility and his/her rates for execution of work will be inclusive of supply of all these items. CONTRACTOR shall not use any of the equipment or materials issued to him by OWNER for installation purposes for laying temporary lines, manufacturing erection aids etc. Misuse of materials will be seriously viewed and deductions at penal rates will be made from the



CONTRACTOR's bills for such quantities that are misused.

- (f) Responsibility for obtaining all statutory approvals related to his construction work lies with the CONTRACTOR.
- (g) The CONTRACTOR shall provide toilet and drinking water, rest room facilities at site for the contract workmen as per statutory requirements at his own cost.
- (h) Earth filled HDPE bags, Shoring and strutting, etc. required for effective retaining of earth fill and excavated pits against water from any source has to be arranged by CONTRACTOR without any extra claim for the entire satisfaction of the or OWNER . Cost for the same is included in the rates for earthwork in filling/cutting items.
- (i) CONTRACTOR has to take all steps to see that normal functioning of Public life/ Public traffic is not affected/obstructed while executing the work. Stacking of materials, excavated earth, equipment and tools should not make any hindrance for the movement of vehicles and people.
- (j) CONTRACTOR shall be responsible for implementing the requirements of Karnataka State Pollution Control Board.
- (k) If the project site have extra organic or inorganic material the contractor company is responsible for its moving for site.
- (l) If the construction area have trees the contractor company is responsible for cutting of trees with their roots from foundation site (no mark cuted trees will be in the site).
- (m) For the normal progress of construction works and accurate supervision of the project the contractor is responsible to hire a civil engineer to be present in the field till completing of the project.
- (n) The site will be provided as and is basis. No additional cost shall be provided on any case.

9.19 STRICT COMPLIANCE WITH SPECIFICATIONS / INSTRUCTIONS

- (a) CONTRACTOR shall observe in addition to Codes specified in respective specification, all national and local laws, ordinances, rules and regulations and requirements pertaining to the Work and shall be responsible for extra costs arising from violations of the same.
- (b) Various procedures and methods to be adopted by CONTRACTOR during the



construction as required in the respective specifications shall be submitted to OWNER in due time for approval.

- (c) CONTRACTOR shall have at all times during the performance of the work, a competent superintendent on the premises. Any instruction given to such superintendent shall be construed as having been given to the CONTRACTOR.
- (d) OWNER reserves the right to inspect all phases of CONTRACTOR'S operations including construction, field and shop fabrication, equipment, assembly, testing. Packing and load-out operations to ensure conformity to the specifications. OWNER will have Engineers, inspectors or other duly authorized representatives, made known to the CONTRACTOR, present during progress of the work and such representatives shall have free access to the work at all times. The presence or absence of an OWNER'S representative does not relieve the CONTRACTOR of the responsibility for quality control in all phases of the work. in the event that any of the work being done by the CONTRACTOR or any SUB-CONTRACTOR is found by OWNER 'S/ 'S representatives to be unsatisfactory or not in accordance with the drawings, procedures and specifications, the CONTRACTOR shall, upon verbal notice of such discrepancy or deficiency, take immediate steps to revise the work in a manner to conform to the relevant drawings, procedures and specifications.
- (e) The CONTRACTOR shall carryout required supervision and inspection as per Quality Assurance Plan and furnish all assistance required by the OWNER in carrying out inspection work during this phase. The or OWNER will have Engineers, Inspectors or other authorized representatives present who are to have free access to the work at all times. If an OWNER'S representative notifies the CONTRACTOR'S authorized representative not lower than a Foreman of any deficiency, or recommends action regarding compliance with the specifications, the CONTRACTOR shall make every effort to carry out such instructions to complete the work conforming to the specifications and approved drawings to the fullest degree consistent with best industry practice.

9.20 DRAWINGS

Drawings accompanying the tender documents are indicative of the scope or work and issued for tendering purpose only. Detailed construction drawings on the basis



of which actual execution of the work is to be proceeded will be furnished to the CONTRACTOR progressively based on the programme evolved after the award of the work.

9.21 ALTERATION IN SPECIFICATION AND DESIGNS

During the execution of the work, the OWNER may desire to make changes in design due to site condition or due to any other reason. The CONTRACTOR shall carry out such changes shown in writing, without any extra cost. These changes shall be either for partially or fully for the entire quantities put to tender, for these items.

9.22 NO ESCALATION

The prices shall be kept FIRM till the completion of work.

9.23 SAFETY, FIRE & SECURITY REGULATIONS

- (a) All the employees of the CONTRACTOR, while working at site, must wear hard hats (helmets) and other protective equipment's suggested by OR OWNER as and when required, depending upon the safety standards and practices without any extra cost.
- (b) First-aid kits must be available at the work spot/site office of each CONTRACTOR and the same shall be replenished from time to time. Officers of OWNER will be inspecting the availability of First-aid boxes at work site.
- (c) The CONTRACTOR has to execute the job without causing any damage to public properties/nearby structures. Any claims in this regard shall be at the risk and cost of the CONTRACTOR.

9.24 PROJECT SCHEDULING & MONITORING

The BIDDER is required to submit a Project Time Schedule in Bar Chart Form, along with the Bid. The Schedule shall cover all aspects like sub-ordering, manufacturing and delivery, sub-contracting and construction within the completion time indicated in the Bid Document. The OWNER interface activities shall be clearly identified with their latest required dates. OWNER reserves the right to disqualify the BIDDER if the above Schedule submitted by the BIDDER is not in line with the overall project requirement.



9.25 PROJECT REVIEW MEETINGS

The CONTRACTOR shall present the programme and status of work at various review meetings as required.

9.26 PROGRESS REPORTS

This report shall be submitted on a weekly basis, covering overall scenario of the work.

9.27 DISTINCTION BETWEEN FOUNDATION & SUPERSTRUCTURE

To distinguish between work in foundation and superstructure the following criteria shall apply;

- (a) For building only (both for stone/brick and RCC works) all works up to level corresponding to finished floor level within the buildings shall be treated as work in "foundation and plinth" and all works above the finished floor level shall be treated as work in superstructure.
- (b) Where not specifically pointed out, all works in cellars/sumps, tanks, cable trenches and other trenches or such similar items would be taken as work in foundations.
- (c) Unless otherwise stated, the rates for various items of work shall be for works at all heights.

9.28 HINDRANCE TO WORK

- (d) The CONTRACTOR may be required to suspend work for a short time/ period in certain areas for the safety requirement. The CONTRACTOR should strictly comply with the instruction from the OWNER from time to time at no extra cost.
- (e) Any obstruction/ hindrance to the work from local public, labours, unions, etc., shall be settled by the CONTRACTOR for successful completion of job within the contractual completion date, as per scope of Contract.

9.29 SAFE MOVEMENT OF VEHICLES/ TIPPERS DEPLOYED BY CONTRACTOR

CONTRACTOR should take extra care for movement of vehicles/ tippers to avoid any sort of accidents to the public, damage to roads, public properties etc. OWNER will not be responsible for any sort of accidents.



9.30 CONTRACT DOCUMENT

- (a) The following shall form the contract documents:
 - (i) Original tender documents issued with its enclosures.
 - (ii) Addendum/corrigendum to tender documents issued if any.
 - (iii) Correspondence exchanged between both parties prior to award of contract and record notes of discussions prior to award of contract.
 - (iv) Telex/Email/Fax of intent awarding the works to the CONTRACTOR.
 - (v) The detailed letter of Intent /acceptance along with statement of agreed variations (if any).

9.31 TAXES AND GOVERNMENT CHARGES

- (a) CONTRACTOR'S quoted CONTRACT PRICE shall be inclusive GST, duties, imports and other charges, with respect to work rendered hereunder whether or not in effect on the date of this CONTRACT but that are imposed, directly or indirectly, prospectively or retrospectively by the Government of India or any other Government.
- (b) The tenderer shall clearly indicate their GST registered number.
- (c) CONTRACTOR before submission of First Invoice for running payment shall register themselves at their own cost with the GST, Income Tax, Sales Tax and such other Central and State Government authorities and all statutory bodies as may be required under the rules and regulations prevailing in India in connection with performance of the work. CONTRACTOR shall bear and pay all registration fees and deposits to authorities in connection with performance of the work.
- (d) CONTRACTOR shall be liable for and shall defend, indemnify and hold OWNER harmless from any claim or liability resulting from CONTRACTOR's failure. The CONTRACTOR shall make timely payment of taxes levied by the Government of India or by the State.
- (e) Any interest, penalty or other liabilities arising because of failure to pay the above items or similar items or failure to comply with the reporting, return or other appropriate procedural requirements with respect to their payment, etc. shall be borne by the CONTRACTOR.



9.32 REGISTRATION UNDER GST

The CONTRACTOR will be required to get registered in GST & Karnataka State and shall furnish the attested copy of certificate for registration under Karnataka sales Tax Act in the proforma prescribed by Government of Karnataka.

Payment of CGST, SGST, IGST & UTGST related clause:

The Contractor are required to adhere the following procedure in order to honour the payment against CGST, SGST, IGST & UTGST in the invoice:

- i. An invoice issued by the supplier of goods or services or both should be in accordance with the provisions of section 31 of the CGST Act and should contain all the prescribed information's in accordance with Chapter VI of CGST Rules, 2017;
- ii. A debit note issued if any, by a supplier should be in accordance with the provisions of section 34 of the CGST Act;
- iii. The supplier should mandatorily upload the aforementioned documents in GSTR -1, details of outward supplies of goods or services within the prescribed time under GST Act;
- iv. The supplier should provide the relevant documents to confirm the tax charged on the invoice has been paid to the credit of government after adjusting with ITC if any.

Notwithstanding above, the supplier should provide indemnification as follows:

“In the event of non-compliances with respect to GST Act and Rules by the supplier, the purchaser is allowed to adjust the GST amount from retention amount (either in BG or in Cash) held by the company. If no amount is available for recovery, the supplier will refund the GST liability within 10 days from the date of GST reversal in GSTRN”

The above requirements are mandatory to claim any GST liability, failing which, the GST liability will not be paid/reimbursed/accepted.

9.33 GENERAL ENVIRONMENT REQUIREMENTS

The CONTRACTOR has to ensure efficient use of natural resources like water, fuel oil and lubricants. The CONTRACTOR should ensure proper awareness to workers to



maintain a green and clean environment inside/outside the plant. The CONTRACTOR must collect and dispose of all the waste and scrap materials at the designated place only as directed by OWNER. CONTRACTOR shall take necessary license for storing Petroleum products at site office from relevant authorities.

9.34 RULES AND REGULATIONS

CONTRACTOR shall observe in addition to codes specified in respective specification, all national and local laws, ordinances, rules and regulations and requirements pertaining to the work and shall be responsible for extra costs arising from violations of the same.

9.35 CONTRACTOR'S LABOURS TO LEAVE SITE ON COMPLETION OF THE WORK

The CONTRACTOR's labours must leave the location of the Project Site/ Township after the work is tapered/ completed to avoid creation of slum areas adjoining the project/township.

9.36 ROUNDING OFF

All payments to and recoveries from the CONTRACTOR shall be rounded off to the nearest rupee. Whenever the amount to be paid/recovered consists of a fraction of a rupee, i.e. if the fraction consists of 50 (fifty) paise or more, the amount shall be rounded off to the next higher Rupee and if the fraction of a Rupee is less than 50 (fifty) paise, the same shall be ignored.

9.37 COMPUTERISED CONTRACTOR'S BILLING SYSTEM

Without prejudice to stipulation, in General Conditions of Contract, CONTRACTOR should abide by the following billing system:

- (a) The CONTRACTOR on their own personal computer will prepare the bills, as per the standard formats and codification scheme proposed by OWNER. CONTRACTOR will submit these data to OWNER in an electronic media along with the hard copy of the bill, necessary enclosures and documents. The CONTRACTOR will also ensure the correctness and consistency of data so entered with the hard copy of the bill submitted for payment. OWNER will utilize these data for processing and verification of the CONTRACTOR's bill. The duly signed hard copy of bill will be considered for making payments.

9.38 ADDITIONAL / EXTRA WORK



OWNER reserves the right to execute any additional works/ extra works during the execution of work, even though such works are incidental to and necessary for the completion of works awarded to the CONTRACTOR.

9.39 TESTING OF MATERIALS:

- (a) The CONTRACTOR without any extra cost shall arrange for testing charges, cost of samples, equipment, personnel, transportation etc. required for the test such as cement, steel, Bricks, solid blocks, sand and other building materials involved in the construction of Armoury House as per the instructions of OWNER.
- (b) The testing shall be carried out at Laboratories approved by the OWNER as per IS standard sampling and for properties and characteristics of material.

9.40 MEASUREMENT , BILLING AND TERMS OF PAYMENTS

The mode of measurement, billing and terms of payment shall be as detailed below:

- (a) Measurement of works:
 - (i) All measurements will be based on latest edition of IS:1200
 - (ii) The CONTRACTOR shall enter all the measurements in Microsoft Excel format and to submit all the bills running as well as final bills in Microsoft Excel format in computer CD's and also hard copies as required by the Engineer-in Charge. Work in general is to be executed as per drawings issued for construction. For all payment purposes, measurements will be based on the actual work executed at site.
 - (iii) Refer "Measurement of Works" in General Conditions of Contract.
 - (iv) Measurement of weights will be in metric tonnes corrected to nearest kilogram and will be made based on the execution drawings (where weights are not indicated on the working drawings, lists as received from the suppliers will be converted to the weights). All other measurements will be as per executed works at site. The weights of weld metal will not be considered.
 - (v) Linear measurements will be in metres corrected to nearest centimetres. If a physical measurement is not practicable, measurements given in the execution drawings shall be adopted.
 - (vi) In case of any dispute as to the mode of measurement not covered by contract to be adopted for any item of work, mode of measurement



as per latest Indian standard specifications shall be followed.

9.41 SCHEDULE OF RATES AND PAYMENTS

- (a) The price to be paid by the OWNER to the CONTRACTOR for the work to be done and for the performance of all the obligations undertaken by the CONTRACTOR and contract rate shall be ascertained by the application of the respective schedule of rates (the inclusive nature of which is more particularly defined by way of application but not of limitations, with the succeeding sub clause of this clause) and payment to be made accordingly for the work actually executed and approved by the OWNER. The sum so ascertained shall (only as and to the extent expressly provided herein) constitute the sole and the inclusive remuneration of the CONTRACTOR under contract and no further or other payment whatsoever shall be or become due or payable to the CONTRACTOR under the contract.
- (b) The prices / rates quoted by CONTRACTOR shall remain firm till the issue of final certificate and shall not be subject to any escalation. Schedule of rates shall be deemed to include and cover all costs, expenses and liabilities of every description and all risks of every kind to be taken in executing, completing and handing over work to OWNER by CONTRACTOR. CONTRACTOR shall be deemed to have known nature, scope, magnitude and extent of work and materials required. He shall make such provision in the schedule of rates, as he may consider necessary to cover the cost of such items of work and materials as may be reasonable and necessary to complete work. The opinion of the OWNER as to the item of work which are necessary and reasonable on completion of work shall be final and binding on CONTRACTOR, although the same may not be shown or described specifically in contract document. Generally this present provision shall not be deemed to cut down or limit in any way CONTRACTOR's obligation under the contract, because in certain cases it may and it may not be expressly stated that contractor shall do or perform a work or supply articles or perform services at his own costs or without additional payment or without extra charge or words to the same effect or that it may be stated or not stated that the same are included in and covered by the schedule of rates.
- (c) The schedule of rate shall be deemed to include and cover the cost of all royalties and fees for the articles and processes, protect by letters, patent



or otherwise incorporated in or used in connection with work, also all royalties, rents and other payments in connection with the obtaining materials or what so ever kind for work. It shall also include an indemnity to the OWNER, which CONTRACTOR hereby gives against all actions, proceedings, claims, damages, costs and expenses arising in the incorporation in or use on work of any such article, processes or materials, octroi or other municipal or local board charges if levied on materials, equipment's, machineries to be brought to site for use, shall be borne by the CONTRACTOR.

- (d) No exemptions or reduction of customs duty, excise duties, sales tax, quay or any port dues, transport charges, stamp duties or central or state govt. or local body or municipal taxes or duties, taxes or charges (from any other body), whatsoever will be granted or obtained, all of which expenses shall be deemed to be included in and covered by the schedules of rates. CONTRACTOR shall also obtain and pay for all permits, or other privileges necessary to complete work.
- (e) The schedule of rates shall be deemed to include and cover risk of all possibilities of delay and interference with CONTRACTORs conduct of work which occur from any cause including orders of OWNER in the exercise of his powers and no account of extension of time granted due to various reasons and for all other possible or probable causes of delay.
- (f) For work under unit rate basis no alteration will be allowed in the schedule of rates because of work or any part of them modified altered, extended, diminished or omitted. The schedule of rates are fully inclusive of rates which have been fixed by CONTRACTOR and agreed to by OWNER and cannot be altered.
- (g) Basic rates :
No basic rates are applicable under this contract.

9.42 BILLING OF WORK

(a) BILLING OF WORK

The CONTRACTOR shall be paid from time to time instalments and interim certificates to be issued by the as indicated in General Conditions of Contract. The CONTRACTOR will submit running account bills in approved proforma after measurement of works as specified in General Conditions of



Contract. The bills can be submitted by the CONTRACTOR when the approximate value of works executed reached the value named in Appendix as “Value of Works for interim certificates” Interim on account payments will be made against certificates issued by based on joint measurement of the work executed.

9.43 RUNNING ACCOUNT PAYMENTS TO BE RECORDED AS ADVANCES

All running account payments shall be regarded as payments by way of advance against the final payment only and not as payment for work actually done and completed and shall not preclude the requiring of bad, unsound and imperfect or unskilled work to be removed and taken away and re-constructed or re-erected or be considered as an admission of the due performance of contract, or any part thereof in this respect or of the accruing of any claim by CONTRACTOR. In addition, the CONTRACTOR shall not conclude, determine or affect in any way the powers of OWNER under these conditions or any of them as to the final settlement and adjustment of the accounts or otherwise or any other way vary or affect contract. CONTRACTOR shall submit the final bill within 20 (twenty days) of the date of physical completion of work, otherwise OWNER certificate of the measurement and of total amount payable for work accordingly shall be final and binding on all parties.

9.44 RECEIPT FOR PAYMENT

Receipt for payment made on account of work when executed by CONTRACTOR must be signed by a person holding due power of attorney in this respect on behalf of CONTRACTOR, except when described in tender as a limited company in which case the receipt must be signed in the name of the company by one of its principal officers or by some other person having authority to give effectual receipt for the company.

9.45 DEFECT LIABILITY PERIOD

- (a) During the defect liability period of 12 months commencing from date of completion of work for which a virtual completion certificate shall be issued, the rectification of defect will be governed by provisions made in “Defects after virtual completion” of General Conditions of Contract.
- (b) If at any time, before work is taken over, the OWNER shall:
 - (i) Decide that, any work done or materials used by CONTRACTOR or any



SUB-CONTRACTOR is defective or not in accordance with CONTRACT, or that work or any portion thereof are defective , or do not fulfil the requirements of CONTRACT (All such materials/works being hereinafter, called 'Defects" in this clause), and

- (ii) As soon as reasonably practicable give to CONTRACTOR notice in writing of the said decision specifying particulars of the defects alleged to exist or to have occurred, then CONTRACTOR shall at his own expense and with all speed make good the defects so specified. In case CONTRACTOR fails to do so, OWNER may take, at the cost of CONTRACTOR, such steps as May in all circumstances, be reasonable to make good such defects. The expenditure so incurred by OWNER will be recovered from the amount due to the CONTRACTOR. Decision of the OWNER with regard to the amount to be recovered from CONTRACTOR will be final and binding on CONTRACTOR. As soon as work have been completed in accordance with CONTRACT, (except in minor respects that do not affect their use for the purpose for which they are intended and except for maintenance thereof provided in General Conditions of the Contract) and have passed the tests on completion, the or OWNER shall issue certificate (hereinafter called Completion Certificate) in which he shall certify the date on which work have been so completed and have passed the said tests and OWNER shall be deemed to have taken over work on the date so certified. If work has been divided into various groups in contract, OWNER shall be entitled to take over any group or groups before the other or others and thereupon the or OWNER shall issue a Completion Certificate which will, however, be for such group or groups so taken over only.
- (c) In order that CONTRACTOR could obtain a Completion Certificate he shall make good, with all possible speed any defect arising from the defective materials supplied by CONTRACTOR or workmanship or any act or omission of CONTRACTOR that may have been noticed or developed, after the work or group of Works has been taken over, the period allowed for carrying out such Work will be normally 1 (one) month. If any defect be not remedied within a reasonable time, OWNER may proceed to do work at CONTRACTOR's risk and expense and deduct from the Final Bill such amounts as may be decided by OWNER. If by reason of any default on the part of CONTRACTOR a Completion Certificate has not been issued in respect of every portion of work, OWNER shall be at liberty to use work or



any portion thereof in respect of which a Completion Certificate has been issued, provided that work of the portion thereof so used as aforesaid shall be afforded reasonable opportunity for completing these Work for the issue of Completion Certificate.

9.46 GUARANTEE FOR REPLACEMENT/ RECTIFICATION WORK

In case the CONTRACTOR is carrying out any rectification work or replacement or such other repairs as mentioned in the above clauses, the said rectification work or replacement or repair shall be guaranteed for a further period of 12 (twelve) months from the date of such work or replacement or repair.

9.47 CERTIFICATE OF VIRTUAL COMPLETION

(a) The works shall not be considered as completed until the OWNER has certified in writing that they have been virtually completed. The defect liability period shall commence from the date of issue of such certificate.

9.48 FINAL DECISION AND FINAL CERTIFICATE

Upon expiry of the period of liability and subject to the OWNER being satisfied that work have been duly maintained by the CONTRACTOR, during monsoon or such period as herein before provided in tender Clause and CONTRACTOR has in all respects duly made up any subsidence and performed all his obligations under contract, the or OWNER shall (without prejudice to any of the rights of OWNER) give a certificate herein referred to as the final certificate to that effect and CONTRACTOR shall not be considered to have fulfilled the whole of his obligation until final certificate shall have been given by the OWNER notwithstanding any previous entry upon work and taking position, working or using of the same or any part thereof by OWNER .

9.49 CERTIFICATE AND PAYMENTS ON EVIDENCE OF COMPLETION

Except the final certificates no other certificate or payments against a certificate or on general account shall be taken to be an admission by OWNER of the due performance of contract or any part thereof or occupancy or validity of any claim by CONTRACTOR.



10. SPECIAL INSTRUCTIONS TO TENDERERS

10.1 EVALUATION CRITERIA

- a) Techno-commercial bid / Pre-Qualification bid shall be opened together and however, the Techno-commercial bid of pre-qualified bidder who meets the eligibility criteria shall be scrutinised and evaluated by the competent committee/ authority with reference to the parameters prescribed in the tender document. Subsequently, in the second stage the financial bids of only technically acceptable offers as decided in first stage shall be opened for further scrutiny and evaluation. Intimation regarding opening of financial bids shall be given to acceptable tenderers to enable them to attend the financial bid opening, if they so desire.
- b) The method of evaluation of bidder for awarding the Contract shall be on consolidated grand total offered by the L1 bidder and will be decided taking into consideration of the total offered price for delivery up to BNPM, Mysore.
- c) Evaluation shall be carried out without considering the GST rates.
- d) Corrigendum/ Addendum, if any, including clarifications provided during pre-bid meeting shall be hosted on Company's website (www.bnpmindia.com) only.
- e) The Company discourages the engagement of agents for brokering contracts and hence intending bidders are requested to take note of the above that engagement of agents for brokering contracts may result in dis-qualification.

10.2 TENDER PRICES:

- a) Tenderer shall quote strictly in INR and as per the attached price schedule. The quoted prices should be inclusive of taxes.
- b) Prices quoted shall be DAP Mysore site basis inclusive of Packing & Forwarding charges, freight, octroi, transit insurance etc. and all other charges if applicable.

11. CONTRACTORS HEALTH AND SAFETY PROGRAMME

11.1 GENERAL

11.1.1 Health And Safety Policy

The CONTRACTOR's shall have HEALTH AND SAFETY POLICY appropriate to the scale and nature of the risks involved in the CONTRACT works. A copy of the POLICY shall be made available to the OWNER during the work. All the CONTRACTOR's



employees/labour shall be familiar with the POLICY. The POLICY shall meet the relevant statutory and regulatory requirements and the requirements. The POLICY shall periodically be reviewed for updating with respect to new and emerging legal and other requirements.

11.1.2 Employee Consultations, Safety Committee And Communication

- (a) The CONTRACTOR shall ensure full involvement of all his employees recognising their right to consultation on health and safety matters. The safety appointees of the various areas, in conjunction with the SR shall be responsible for ensuring employees' involvement through routine safety inspections, hazard and risk assessment in new and changed works and their control. The CONTRACTOR shall maintain appropriate operating procedures to guide these requirements.

11.1.3 The CONTRACTOR shall communicate to the employees regularly on job hazards applicable to their tasks in hand. Meetings with SUB-CONTRACTORS attended by the representative of CONTRACTOR to discuss hazards and risk assessments, job safety analysis and control procedures and to review accidents and incidents (Near-miss) for remedial measures to prevent such occurrence.

11.1.4 CONTRACTOR's Accident/Incident Reports

- (a) 'Accident' for the purpose of this Para is defined as 'Undesired Event Giving Rise to Death, Ill-health, Injury, Damage or other Loss' and 'Incident' is defined as 'Event that gave rise to an Accident or had the Potential to lead to an Accident'. An accident where no ill health, injury, damage or other loss occurs is also referred to as 'Near-Miss'. Incident includes Near-Miss. The CONTRACTOR shall report orally, to the or OWNER regardless of their extent, duration and severity, immediately on occurrence of all accidents resulting in:
 - (i) Personal Injury
 - (ii) Property damage
 - (iii) Fires
 - (iv) Spills
 - (v) Near-Misses
- (b) The CONTRACTOR shall submit the accident and incident report in writing to the OWNER within 24 hours of its happening in the form as prescribed by



the governing statute or in the absence of which, in the form prescribed by the OWNER. The CONTRACTOR shall detail in the 'Accident/Incident Report', the particulars of the dangerous occurrence leading to the accident, lost time of absence due to accident, root cause analysis and the corrective and preventive actions to prevent such recurrence. In addition, the CONTRACTOR shall include his estimate of the impact of accident on project schedule. Incidents shall also be reported in the same manner identifying root cause/s to eliminate such potential occurrence or risks.

11.1.5 Work Permits

(a) The CONTRACTOR shall maintain a work permit procedure to limit the hazardous processes and high risks tasks to authorised personnel, who shall be informed of the job safety analysis and the job specific safety precautions, on issue of a work-permit.

(b) Safety Work Permit (SWP)

SWP is mandatory for working at heights, on fragile roofs such as asbestos or such roofing works, steel erection, work over water, a live substation or switch-yard even if section of work is not electrically charged, demolition, blasting and such potentially hazardous CONTRACT works in the opinion of the or OWNER .

(c) Hot Work Permit (HWP)

HWP shall be used where hot working, like electric or gas welding, gas cutting, or burning or any other operation involving heating, open flames or electric arcs, grinding and electrical works etc. are potentially dangerous in areas such as inflammable materials storage, plant and pipe lines handling inflammable and or explosive materials either presently or in the past, or where new works are undertaken adjoining such works which in the opinion of the OWNER are potential risks. A HWP shall be deemed mandatory in all such potentially dangerous areas. The CONTRACTOR shall get areas such as welding shops or maintenance areas approved by the OWNER for 'Permit-Free' operation.

(d) Confined Space Entry Permit (CSP)

CSP is issued for entering and carrying out tasks in confined space. Confined space for the purpose of this Para is defined as an enclosed or partially enclosed space which is not intended or designed primarily as a work place and



- (i) Is at atmospheric pressure during occupancy
 - (ii) Has restricted entry and exit
 - (iii) Has potentially harmful level of toxic or inflammable contaminant or unsafe level of oxygen
 - (iv) Is of a nature that could contribute to overwhelming a person by an unsafe atmosphere
 - (v) Has a potential that safety on entry could be affected by unsafe conditions stated above by accident or due to human errors
 - (vi) Confined spaces shall include but not limited to storage tanks, process vessels, bins, boilers, ventilation or exhaust ducts, sewers, underground utility vaults, tunnels, pipelines and open top spaces more than 4 feet in depth such as pits, tubs, vaults and vessels.
- (e) Electrical Safety permits/Lock-out and Tag out (ESP/LOTO)

The CONTRACTOR shall institute an electrical safety permit system to ensure safe electrical isolation. Safety permits shall not be issued until safe release tag is placed on the equipment isolated on all isolating points. The safety permit shall be returned on satisfactory completion of the job by the executing agencies duly signing off indicating that all shorts and grounds and men and materials are removed from the job and that the job safe for energising. This is a prerequisite to energise the isolated equipment. The safety tags shall be collected in the order first the isolated equipment and lastly the tag on the main control of the equipment the tags and permit system shall be auditable.

11.1.6 Job Safety Inspection

- (a) The CONTRACTOR shall maintain a procedure for Safety Inspection at routine intervals to provide assurance that the instituted safety procedures are in place to prevent deviations from established standards that could lead to a safety hazard and consequential risk. The CONTRACTOR shall establish appropriate standardised checklists for systematic job safety verification to ensure
- (i) Standards are followed without deviation
 - (ii) Employees are competent to perform as per prescribed operation



- control procedures,
- (iii) Monitoring of safety of the various work areas/tasks and
 - (iv) Adequacy of existing operation control procedures and practices to mitigate and eliminate risks
- (b) Should the existing operation control procedures prove inadequate and the residual risks are higher than tolerable levels, the SR shall initiate hazard and risk assessment and analysis and consultations with the SC to deploy appropriate remedial measures and improved operation control procedures. Periodic inspection reports and proposed remedial measures shall be submitted to the OWNER. Records of changes change processes; consultations with the SC and revision of operational controls shall all constitute objective evidence of the existence of established procedures.

11.2 EQUIPMENT, SUBSTANCES AND PERSONAL SAFEGUARDING

11.2.1 MECHANICAL SAFETY

- (a) The CONTRACTOR shall ensure that all his equipment and machinery are safe to use while in motion or working. Operators shall have received training or instruction on operation of the machinery and the regulatory requirements. The CONTRACTOR shall have adequate procedure to ensure the stability and securing of his working machinery during operation. He shall restrict repair and maintenance of the machinery to trained personnel and maintain records of repairs and maintenance. The equipment shall have appropriately designed means of isolating from sources of energy and shall have emergency stop control, which is easily accessible. All controls shall be clearly and uniformly marked. All operation controls, interlocks, sensing devices and guards on tools and equipment shall be functional and their status shall be regularly checked and recorded. The CONTRACTOR shall provide evidence of compliance to these requirements in any contractual write-ups submitted to the OWNER for approval in respect of critical construction/contract works.
- (b) The CONTRACTOR shall provide only good quality hand tools and ensure control of condition, storage, routine inspection and use of such hand-tools. Unsafe tools such as with cracked or broken handles, mushroomed chisels and punches, worn screwdrivers, hardened hammerheads; power tools with unsafe resistance to earth or without safety guards shall be prohibited.



- (c) All safety ladders, scaffolding and such access equipment shall meet requirements of IS 3696 and IS 4014 and such standards as the OWNER may stipulate. The safety work permits shall be issued only after ensuring that all safety requirements of access equipment are complied with. Access equipment shall be inspected on a routine basis to prevent injuries caused by falls.
- (d) The CONTRACTOR shall ensure safety of all those concerned with lifting and those who may be affected by material hoisting, lifting and handling using various mechanical aids. All lifting equipment such as cranes, hoists, lifting shackles, hooks chains and links shall be designed as per appropriate International codes of construction. Operators shall have been trained in operation and maintenance of such equipment besides training on standard hand signals to be employed during the hoisting and lifting operations. Safe Working Loads (SWL) shall be marked on equipment prominently. SWL shall be evidenced to have been established by test procedures in accordance with acceptable codes of practices.
- (e) Riding on construction equipment, forklifts and cranes shall be prohibited unless such vehicles are provided with passenger seats.
- (f) Pressurised gas and air systems shall be maintained safe in good working order and shall meet the requirements of the Factories Act 1948, The Static and Mobile Pressure Vessels Rules 1984 and the Gas Cylinder Rules 1934 as applicable. The safety relief valves, safety appurtenances and isolation systems shall be compliant with safety code of practices. Any statutory register of pressure vessel records and the code of practices shall be subject to periodic auditing by the OWNER.
- (g) The areas of highly dangerous activities like hoisting, lifting and rock blasting, and radiation, shall be appropriately barricaded to protect personnel and machinery and guided by work permit discipline. Emergency plans shall cater to emergencies arising out of such activities.
- (h) Signs, barricades, barrier tapes and warning or entry restriction devices or accessories shall be provided to minimise work related risks of accidents and injuries. Signage shall meet all regulatory requirements such as under The Building and other construction workers Act 1996, Factory Act 1948, Manufacture, Storage, Import of Hazardous Chemicals Rules under Environmental Protection Act 1986, Indian Explosives Act 1984 and Gas Cylinder Rules 1981 and Indian Electricity Act 1910 and Rules thereof and



any other safety requirements of the or OWNER .

11.2.2 ELECTRICAL SAFETY

- (a) The CONTRACTOR shall provide only such equipment for work that is electrically safe to work. The CONTRACTOR shall have a procedure to identify and record all his electrical equipment in a register, with provisions to record his periodic inspections of such equipment. Inspection shall cover cables, extension leads, all electrical equipment drawing power from socket outlet. He shall identify and maintain in good working order all electrical installations such as distribution panels and major switchgear ensuring safe accessibility. A clear area shall be maintained around panels and switchgears. The installed equipment shall be periodically inspected by qualified personnel to ensure their continued safe operating condition. Inspection shall include earth polarity checks, continuity checks and earth resistance checks. The CONTRACTOR shall ensure use of flameproof and explosion proof switchgears and lighting fittings where required as per governing codes.
- (b) Approved earth leakage relays or alternative safety devices to relevant IS and International codes shall be used on all portable electrical hand tools. Where possible low-voltage electric power supply shall be used for hand tools, earth leakage units shall protect electrical installations in workshops, kitchens, cafeterias, first-aid rooms, laboratories and offices. Record of regular checks shall be maintained. The CONTRACTOR shall comply with 'Code of Practice for Earthing' as per IS 3043.
- (c) Safety rubber matting of appropriate voltage rating conforming to IS 5424 entitled 'Rubber Mats for Electrical Purposes' shall be provided in front of all switchgears and power distribution panels for the safety of personnel operating such equipment.
- (d) The CONTRACTOR shall arrange displaying signage under Indian Electricity Act 1910, such as:
 - (i) Danger notices as per IS 2551 in conspicuous places on all low, medium and High voltages as per Rule 35,
 - (ii) Instruction of restoration of persons suffering from electric shock in English and local languages as per Rule 44 in switchgear rooms, substations and places where electricity is used and
 - (iii) Notice prohibiting unauthorised entry in areas where



electrical apparatus are used.

- (e) All power cables providing construction power to various construction machinery and the connectors shall be in safe and sound condition. Cables shall be routed through cable trays supported on appropriately designed structures, duly clamped, secured and identified. Road crossing cables shall be laid in conduits buried at least 600 mm below the surface to prevent damage due to vehicular traffic. All cables shall be off the floor to avoid damage or tripping hazard. Cables shall be terminated at the switchgear and sockets in a workman like manner to prevent loose contacts and flashover. Only safety receptacles shall be used for providing power connection to hand-tools. All switches and distribution boards shall be clearly marked. All electrical distribution and panel wiring diagrams shall be available with the electrical maintenance personnel. The CONTRACTOR shall maintain a safe electrical isolation/lockout procedure.
- (f) The CONTRACTOR shall ensure lighting circuits are not used for hand-tools. No electrical equipment shall be overloaded. Tools and test equipment used on electrical systems shall be insulated.

11.2.3 SUBSTANCES ABUSE PROGRAMME

The CONTRACTOR is encouraged to have a 'Substance Abuse Programme', and pre-employment drug testing. Drinking during working hours shall be strictly prohibited. The CONTRACTOR shall promote through poster and other publicity, awareness on abuse of substances such as alcohol and such depressant drugs that slows the activity of brain and spinal cord on abusive usage endangering the safety and health of users and others affected by their work.

11.2.4 HAZARDOUS SUBSTANCES CONTROL

- (a) The CONTRACTOR shall prevent all injuries, illnesses and damage to property or the environment caused by any article or substance, which proves to be hazardous. The code of practices of construction and operation and maintenance and control procedures shall meet required statutory and regulatory requirements. Personnel shall be trained on use, handling, storage, disposal and emergency spillage procedures.
- (b) The CONTRACTOR shall detail and deploy operational controls to reduce hazardous wastes and their disposal as required by the statute 'Hazardous Waste (Management and handling) Rules 2000'. Oil wastes, used oils, soil



and cotton soaked in oil consequent to handling operations, grease and many class of paints and asbestos sheets and gaskets are typical hazardous wastes.

- (c) The CONTRACTOR shall identify, contain and control all sources of radiation. Appropriate regulatory approvals shall be obtained before commencement of work involving radiation sources. Radiation protection advisors suitably qualified and experienced shall be appointed whose names shall be submitted to OWNER. Dosimetry and surveillance of personnel engaged in such work shall be maintained in accordance with regulatory requirements.

11.3 PERSONAL SAFEGUARDING

11.3.1 PERSONAL PROTECTION EQUIPMENT (PPE)-GENERAL

The CONTRACTOR shall provide his employees required PPE meeting the requirements of the stated IS specifications and guidelines or equivalent International Standards as may be prescribed by the or OWNER from time to time. The CONTRACTOR shall have instituted good working procedures and practices in providing PPE, maintenance, issue and training on their use. All PPE shall be periodically checked to ensure worn, damaged equipment are replaced expeditiously.

- (a) Control Issue, Use and Maintenance of the PPE

Employees should be responsible for the PPE issued to them. The CONTRACTOR shall meet requirements of IS 8519 entitled 'Guide for Selection of Industrial Safety Equipment for Body Protection' or any equivalent international specification that the OWNER may prescribe.

- (b) Head Protection

The CONTRACTOR shall comply with requirements of IS 2925. Hard hats shall be used and worn where a hazard of falling or flying objects exist. Hard hats intended for use by visitors shall have replaceable paper lining.

- (c) Eye and Face Protection

Eye protection shall be worn during all operations by operators and people in the vicinity, where there is a danger of flying particles of metal such as generated during use of hand tools such as chisels, grinding, welding and cutting lathe work on brass and cast iron acid and alkali splash, high pressure jet cleaning or insulation removal from heights using high pressure



jets. The CONTRACTOR shall meet the requirements of IS 8520 entitled 'Guide for Selection of Industrial Safety Equipment for Eye, Face and Ear Protection'.

(d) Footwear

Safety shoes, boots and gumboots fitted with steel toe-caps of approved quality conforming to prescribed Indian or international standards. Wearing of unsafe safety shoes such as jogging shoes, tennis shoes, slippers and sandal etc. are prohibited. The CONTRACTOR shall meet the requirements of IS 10667 entitled 'Guide for Selection of Industrial Safety Equipment for Protection of Foot and Leg'.

(e) Protective Clothing

The CONTRACTOR shall prevent hazards of loose clothes worn by workmen getting caught in moving machine parts. Loose and thin garments such as dhoti and pyjamas are prohibited. While the CONTRACTOR shall ensure that all workmen wear long sleeved shirts, jackets or the like with the sleeves rolled down and secured at the cuff, long pants/ trousers extending upto the top of the safety shoes so as to prevent injuries caused by contact with heat, cold abrasive and sharp surfaces shall be strictly enforced. Such protective clothing shall be mandatory in hazardous areas especially during start-up operations involving hot, inflammable, and other chemical hazards, furnaces and Boilers and such fired equipment and asphaltting plants. Personnel exposed to acids and alkalis hot fluids and steam during such operations shall be provided with appropriate heat or corrosion resistant clothing. The CONTRACTOR shall meet the requirements of IS 8990 entitled 'Maintenance and Care of Industrial Safety Clothing'.

(f) Hand Protection

The CONTRACTOR shall provide appropriate hand gloves as per IS 8807 entitled 'Guide for Selection of Industrial Safety Equipment for Protection of Arms and Hands' to prevent injuries to hands during work. The CONTRACTOR shall maintain appropriate inventory of gloves for different applications like acid and alkali handling, general-purpose work gloves and asbestos or heat resistant hand gloves etc.

(g) Safety Harness or Fall Arrest

The CONTRACTOR shall provide safety harness or means of restraint such as safety belts, harness and lifelines etc. to workmen engaged to work in



heights such as open-sided floors, open-sided scaffoldings, floor and roof openings, overhead construction works of various nature etc. where there is a falling hazard of two metres or above. Storage, issue, wearing and maintenance of safety harness shall be under strict supervision and records shall be maintained. All fall arrests shall consist of full-body harnesses, lanyards with shock absorbers, lifelines, rope grabs and associated hardware. Two alternate lanyards shall be used to facilitate tying off at a new location before disconnecting from the previous location. Practices for safety harnesses and fall arrests shall conform to IS 4912, IS 11972 and IS 8519 or equivalent international codes.

(h) Falling Object Protection

Where work is in progress in elevated areas, barricades, barrier tapes, signs and such entry restriction devices shall be used to keep area below clear of personnel to prevent injury due to falling objects. If work is required in the area below elevated work area, it shall be scheduled at a time different from elevated works. The workmen below shall be protected from falling objects by the debris net or a catch platform with an adequate toe board to prevent material from falling off. Use of safety net for elevated works shall be considered in the work-permits where appropriate. Where a lift is made above a working area, the area below the path of the lift shall be cleared of personnel during the lift and barricaded and guarded to prevent entry of persons generally in conformity with IS 4912, IS 11972 and IS 13416 for protective barriers in and around building and preventive measures against safety hazards in work places and safety requirements for floor and, wall opening, railings and toe-boards.

(i) Respiratory Equipment

The CONTRACTOR shall maintain where appropriate, procedures for training and use of Self-Contained Breathing Apparatus (SCBA). The SCBA shall be provided together with lifelines and rescue teams to safeguard personnel working in areas where gases such as carbon monoxide, methane chlorine and such life endangering atmospheres are present. The CONTRACTOR shall meet requirements of IS 9623 for 'Selection, Use and Maintenance of Respiratory Protective Devices'. The CONTRACTOR shall have trained adequate number of personnel including the identified firefighting teams, hose teams and SAs in the use of the SCBA. The CONTRACTOR shall use the periodic safety drills to demonstrate, train and establish competence of personnel in the use of SCBA.



(j) Hearing Conservation

The CONTRACTOR shall ensure reasonable precautions are taken to avoid injury to the hearing of the employees. All noise levels shall be controlled within 85 dBA. The CONTRACTOR shall identify noise areas where noise levels exceed prescribed safe level for arranging for appropriate engineering revision. Where this is not feasible, appropriate earmuffs or protectors shall be provided to workmen ensuring these are worn by those exposed to noise levels beyond safe levels. Periodic hearing acuity tests shall be conducted on such persons exposed to high noise levels to ensure that they do not suffer any hearing impairment as per requirements of IS 8520.

11.3.2 MANUAL HANDLING AND ERGONOMICS

- (a) The CONTRACTOR shall have procedures to identify risks involved in manual handling operation and tasks. The CONTRACTOR shall ensure appropriate training to prevent any possible injury. Full use of mechanical aids shall be made to avoid risks arising out of such manual handling. Employees shall be adequately trained on such manual tasks and related safety precautions to reduce the risk of injury to personnel engaged in such work.
- (b) The CONTRACTOR shall undertake ergonomic study of manual operations to prevent musculoskeletal injury during manual handling, besides visual fatigue and mental stress giving considerations to matters such as seating lighting and ventilation etc.

11.4 FIRE PROTECTION AND PREVENTION

11.4.1 GENERAL REQUIREMENTS

- (a) Where the OWNER maintains the fire protection equipment, the CONTRACTOR shall comply with the OWNER's fire regulations, warning signals and procedures. The CONTRACTOR shall arrange to train his personnel meeting the prescribed qualifying competence needs, in requisite numbers in the operation of such fire protection equipment and systems.
- (b) Risk assessments shall be carried out to identify potentially vulnerable areas to provide sufficient quantities of correct type of extinguishers and ancillary equipment to deal with various types of fire hazards.
- (c) Where required under the Contract the CONTRACTOR shall provide



appropriate type of extinguishers close to areas of fire hazard but not too close they are cut off from use during a fire. Water based extinguishers shall not be positioned close to or used on electrical equipment.

- (d) Extinguishers shall be marked/labelled and recorded with location particulars in a register. These shall be inspected at monthly intervals to ensure they are in operable sound condition. There shall be a systematic plan for servicing, repairing and recharging fire extinguishers and for recording such dates on the register and equipment.
- (e) The location of firefighting equipment shall quickly and easily be identifiable especially in emergencies in a conspicuous manner painted as high as possible to identify the location of the extinguisher to prevent it from being obscured by machinery and goods stacked in front and to return the equipment to its location after emergency use in other locations. In order to ensure this, 'Keep Clear' area shall be demarcated and maintained. Location plans of extinguishers and fire- fighting equipment shall be prominently displayed when desired by the OWNER.
- (f) SR and SAs shall be trained on firefighting techniques who shall co-ordinate and control fire protection and prevention programmes.
- (g) Where required under the Contract, the CONTRACTOR shall maintain alarm systems powered by mains and by battery for back-up. Where required under the Contract, emergency lighting shall be provided to aid evacuation in poor lighting conditions following the alarm. The alarm system shall be made known to all employees. When the OWNER extends these facilities for use by the CONTRACTOR, he shall provide appropriate training to his personnel in the use of such emergency facilities and duties
- (h) A clear written procedure for action in the event of fire should be produced. Fire teams and hose teams shall be identified and their responsibilities during emergencies shall be detailed in writing. Personnel shall be trained on their fire duties and use of fire-fighting equipment. Regular drills shall be conducted to test procedures and to validate them. Fire instructions and emergency procedures shall be displayed throughout the premises. Emergency response procedures are detailed under Para 5.0 below.
- (i) A means of escape shall be provided in all work areas and storages and maintained and kept free from obstruction. All exits shall be clearly marked and kept unlocked whilst the premises are in use. Escape routes shall be protected from fire.



- (j) When a hot work permit is issued, the CONTRACTOR shall ensure
 - (i) Identification of combustibles such as paper, cardboard and wood and moving away from area where hot work is undertaken using open flame or electric arc.
 - (ii) Determination that flammable vapours and liquids are not present
 - (iii) Protection of floor and wall openings to keep out sparks
 - (iv) Determination that sprinkler and hydrant and other installed fire systems are functional
 - (v) Establishing a fire-watch with fully loaded extinguishers or charged water-hoses throughout the operation and 30 minutes after completion of operation adequate ventilation for welders, by means of natural air movement,
 - (vi) Exhaust ventilators or air-line respirators as required
 - (vii) Workmen performing the task are adequately briefed on job safety analysis, hazards and risks and the safeguards against risks.

11.4.2 SECURITY

- (a) Where required under the contract, security personnel shall do all that is reasonably practicable to ensure the safety of employees and property of the company in the face of accidents by fighting fires and containing losses due to pilferage, theft, vandalism and industrial espionage both by employees and external elements. Security personnel shall be appropriately competent and receive adequate safety training. Security personnel shall routinely report on a standardised basis on aspects such as violation of fire-protection rules, use of alcohol and narcotic drugs, condition of security fencing, floodlighting and storages etc.
- (b) Where the project is located where a number of other companies are in operation, the CONTRACTOR shall plan for mutual assistance programmes in cases of emergencies, as are practiced in the area in conjunction with the OWNER.
- (c) Where common boundaries exist between companies, the CONTRACTOR in conjunction with the OWNER shall co-ordinate security control over factors common: such as floodlights, fencing, pipelines containing gas, fuel and electricity



(d) Security personnel shall be represented in the SC through the SA nominated from the area.

11.5 EMERGENCY PLANNING (EP)/EMERGENCY RESPONSE (ER)

11.5.1 The CONTRACTOR shall plan to deal with emergencies. An EP/ER specific to the job site shall be written and communicated to all employees. The EP/ER shall identify for the potential for and responses to incidents and emergency situations and for preventing and mitigating the likely illness and injury that may be associated with them.

11.5.2 The CONTRACTOR shall review his emergency preparedness and response plans and procedures in particular after occurrence of incidents or emergency operations

11.5.3 The CONTRACTOR shall designate his emergency team with their duties during emergencies defined, including those of the hose teams, medical personnel, first-aiders and security. The CONTRACTOR shall maintain a procedure as to how his emergency organisation shall liaise with the OWNER's representatives in the EP/ER.

11.5.4 The CONTRACTOR shall also periodically test such emergency procedures by conducting mock-drills and use the experience for updating the EP/ER and for training the employees on the perceived competence needs.

11.5.5 The EP/ER of the CONTRACTOR shall be under the control of the SR who shall be able to co-ordinating with the or OWNER for liaising with government agencies, neighbouring industries and community

11.5.6 The EP/ER shall be designed to allow people to work under disaster conditions when normal services such as telephone water, light power, transport and sanitation are not available and first aid and firefighting facilities are not able to cope with sudden demand on services.

11.5.7 The telephone numbers of ambulance, police, managers and the OWNER's key executives shall be prominently displayed in the identified Emergency Response Centre.

11.6 PREMISES AND HOUSE-KEEPING

11.6.1 ORDERLY WORK-PLACE

The CONTRACTOR shall maintain a well-managed safe working place in sound clean



condition. The CONTRACTOR shall ensure that there is a place for everything and everything in its place so that optimum use is made of valuable floor space with commensurate cleanliness and reduced handling time. He shall ensure that his entire infrastructure including temporary and semi-temporary buildings are kept clean and good repair.

11.6.2 GOOD LIGHTING-NATURAL AND ARTIFICIAL

The CONTRACTOR shall provide lighting natural or artificial to enable work Processes are carried out safely. Artificial lighting shall be adequate especially in the nights and emergencies. The lumen levels shall meet the statutory requirements.

11.6.3 VENTILATION-NATURAL AND ARTIFICIAL

The CONTRACTOR shall ensure that workplaces are ventilated with at least prescribed amount of clean or cleaned fresh air of a suitable temperature, especially where toxic or irritating substances are present such as welding, vehicle exhaust fumes, irritating dusts, organic solvents or any other inimical atmosphere creating health hazards or safety.

11.6.4 WELFARE AND HYGIENE FACILITIES

The CONTRACTOR shall provide welfare facilities to ensure a high standard of cleanliness for all activities and rest. The CONTRACTOR shall provide facilities for his employees such as ablutions, toilets change rooms, kitchens and cafeterias adequate and in a clean and hygienic state.

11.6.5 POLLUTION TO GROUND, AIR AND WATER

The CONTRACTOR shall strive to exceed established minimum performance norms in waste and pollution control. All drains shall be identified as clean water and foul water to aid non-armful disposal.

11.6.6 TRAFFIC ROUTES AND AISLES

The CONTRACTOR shall arrange to separate pedestrian and vehicular including material handling equipment traffic wherever possible and maintain the routes clear of obstruction. To ensure safety of user's clear painted demarcation is encouraged as a discipline to be enforced.

11.6.7 STACKING AND STORAGE PRACTICE



- (a) The CONTRACTOR shall ensure stacked material is bonded on a stable and level footing capable of carrying the mass of the stack. Adequate clearances shall be provided between the sides of the stack and top to facilitate unimpeded access to service equipment like overhead wiring, cranes, forklifts and firefighting equipment, and hoses. Circular items shall be sufficiently choked with wedges not with odd bits of materials. Free-standing stacks of gunny bags and sacks such as cement bags shall be stacked to prescribed safe-stack heights with layers formed for stable bonding, preventing slippage causing accidents. Stacking against walls shall not be permissible.
- (b) The CONTRACTOR shall maintain the premises and surrounding areas in clean and clear manner with safe access and egress. There shall be sufficient and adequate storage racks, shelving, bins and pallets and material handling equipment to stack his construction materials such as pipes structural and construction enabling materials. Unwanted materials shall be promptly moved away for efficient material movement.

11.6.8 STORAGE OF HAZARDOUS MATERIALS

- (a) Hazardous materials shall be stored on solid bases. Solid bases shall include compacted earth, pallets, concrete or asphalt platforms or paving. Hazardous materials shall be stored, stacked and secured to prevent toppling, spillage or other unintended dislodgement. Aisles and clearances shall be as detailed under clause 11.6.6 above. Hazardous materials shall be stacked in such a manner that an observer standing in the aisle can read their labels and legend.
- (b) Each hazardous material contained shall be identified by a legible label or legend as per governing statute, code or regulation. The label shall identify the item, quantity and appropriate warnings.
- (c) Hazardous materials which if brought in contact with each other could react or pose equal or greater hazard than either material stored alone shall be stored at a distance not lesser than twenty feet apart.
- (d) Warnings shall be posted and maintained in a legible condition at all access points clearly defining the specific hazardous nature of the stored materials such as 'Corrosive', 'Flammable', 'Explosive', 'Oxidising', 'Compressed Gas' or other hazardous nature.
- (e) Where hazardous materials are unloaded in the CONTRACTOR's storage



maintained at site in a semi-permanent installation, such installations shall be approved by relevant statutory bodies. Copies of licences for storage shall be lodged with the OWNER. The containers and storage shall display quantities stored with name of the hazardous material and the UN hazard classification label in prescribed colour code prominently painted in a conspicuous manner.

- (f) The CONTRACTOR shall inspect the hazardous storages and installations on a daily basis and shall undertake any requisite preventive action necessary to avoid safety risks

11.6.9 STORAGE OF FLAMMABLE AND EXPLOSIVE MATERIALS

- (a) The CONTRACTOR shall secure flammable and or explosive materials against accidental ignition.
- (b) Storage facilities for flammable liquids such as petrol, diesel kerosene and lubricants as well as the quantities stored shall meet the legal and statutory requirements. These shall be stored in approved fire-resistant rooms with a sump of sufficient volume to contain any spillage.
- (c) The electrical fittings to be flame -proof and on a strict maintenance schedule. Containers shall be appropriately bonded in receptacles into which low flash point fuel is decanted.

11.6.10 COMPRESSED GAS CYLINDERS

Compressed gas cylinders shall be stored and secured in the upright position at safe distances from shielded from welding and cutting operations. Compressed gas cylinders in storage shall be shut off and torches, hose and manifolds removed and capped. Cylinders shall be periodically checked for leakages. Storage shall meet requirements of Gas Cylinder Rules 1981. Compressed gas storages shall be provided with safety relief valves, Safety valves and rupture disc to protect them overpressures. Appropriately designed to ensure their continued availability in the face of process changes

11.6.11 SCRAP AND REFUSE BINS-REMOVAL SYSTEM

The CONTRACTOR shall ensure that he has sufficient waste bins that are identified for different wastes and maintained in clearly demarcated areas. Wastes with oily or other ignitable materials such as oily cotton wastes and hand gloves shall be stored separately with covers to prevent fires and shall be made of metal. Different wastes shall be segregated and stored separately and disposed off. These shall be emptied



at routine intervals to prevent that they do not overflow with wastes.

12. SAFETY CONDITIONS FOR UNDERTAKING SITE WORK

This document gives broad guidelines to be followed by the CONTRACTOR for ensuring safe working conditions in and around the site.

12.1 SAFETY ORGANISATION

12.1.1 CONTRACTOR at site shall organise a Safety Group headed by a Safety Officer who shall be responsible for providing, supervising and monitoring safe working conditions at all times for their workers. The Safety Officer shall be experienced in maintaining safe conditions for workers at site and shall be responsible for and shall have authority to enforce safe conditions for the workers.

12.1.2 The CONTRACTOR shall have a declared Safety Policy and shall get the same approved by the OWNER. The approved Safety Policy shall be displayed prominently in the CONTRACTOR's site office.

12.1.3 The CONTRACTOR shall take active interest and participate in the development and operation of safety programs at site. His responsibility does not cease with establishment of Safety Group and approval of its various activities. He shall demonstrate his involvement by regular participation in safety meetings, review of safety records and taking corrective action where required, introduction of safety promoting bulletins, posters, suggestions and awards and by setting example by strictly observing safety rules.

12.1.4 The CONTRACTOR shall remove all waste material and debris from and around the work area and properly clean up the area at the end of each day before leaving the work site.

12.1.5 The CONTRACTOR shall take all necessary precautions not only for safe working of his own workmen but also deploy all precautions to ensure safety of structures, equipment and workmen of other agencies in and around his work site.

12.1.6 The CONTRACTOR shall ensure that his workmen do not trespass into prohibited areas.

12.1.7 The or OWNER shall have the right to inspect at any time, all items of machinery or equipment brought to site by the CONTRACTOR, his agents or workmen and to



prohibit the use on the site of any item, which in the opinion of the or OWNER is or may be detrimental to the safety of the site. The exercise of such right or the omission to exercise it in any particular case shall not absolve the CONTRACTOR or his agents or workmen of their responsibility of adhering to the safe working practices.

12.1.8 The CONTRACTOR shall execute the work in a manner causing the least possible interference with the business of the OWNER , or with the work of any other CONTRACTOR who may be engaged on the premises and shall at all times cooperate with the other CONTRACTORS working at site.

12.1.9 The CONTRACTOR shall obtain work permit from the OWNER before starting any work at site. The work permits are issued to prevent the CONTRACTOR from working in unauthorised areas and shall be valid for specific area for a stipulated period

12.1.10 The CONTRACTOR shall ensure at all times that his workers do not lie down or sleep under or around any machine, equipment, vessel, vehicle or structures in his work area.

12.2 RESPONSIBILITIES OF THE CONTRACTOR'S SAFETY OFFICER

12.2.1 He is responsible and accountable for:

- (a) Preventing injury to personnel, damage to plant and equipment and fires.
- (b) Instituting ways to improve existing work methods from safety point of view.
- (c) Legal and contractual requirements affecting safety, health, and welfare of his workmen
- (d) Provision and use of protective clothing and equipment and use of firefighting equipment
- (e) Suitability of new and hired equipment from a safety viewpoint
- (f) Identifying potential hazards.
- (g) Changes in safety requirements and fire precautions



- (h) Carrying out site surveys to see that only safe work methods are in operation, health and safety requirements are being observed and welfare and first aid facilities are adequate and properly maintained.
- (i) Determining the cause of an accident or dangerous occurrence and recommend means of preventing recurrence.
- (j) Supervising the recording and analysis of information on injuries, damage and production loss. Assess accident trends and review overall safety performance.
- (k) Assisting with training of employees at all levels. Organising periodic demonstration of practising safe working conditions by experienced safety instructors.
- (l) Taking part in discussions on injury, damage and loss control.
- (m) Keeping up-to-date with recommended codes of practice and safety literature. Circulating information applicable to each level of employees.
- (n) Fostering within the company an understanding that injury prevention and damage control are an integral part of business and operational efficiency.
- (o) Attending job progress meetings where safety is an item on the agenda. Report on job safety performance.

12.2.2 The Safety Officer shall inspect and ensure the following:

- (a) All electrical equipment are securely earthed.
- (b) Standard access platforms and ladders are provided for inspection, operation and maintenance of equipment.
- (c) The equipment are periodically inspected for their condition, maintained
- (d) Properly and operated by trained personnel at design speeds and loads.

12.3 WORKING AT HEIGHTS

For carrying out work at heights exceeding 2 meters or near openings in floors and roofs etc. precautions as given in following paras shall be taken.



- 12.3.1 Adequate safety precautions like use of safety belts, crawling-ladders, safety nets etc. shall be taken. The workers shall wear safety belts with hook properly fastened.
- 12.3.2 All workmen engaged on work at heights shall be experienced in such work.
- 12.3.3 Written permission of the OWNER shall be obtained before undertaking work on roofs.
- 12.3.4 Wherever possible, steel staging or platform shall be erected.
- 12.3.5 Staging with toe guards shall be provided with simple safety rails or ropes at waist height throughout its length on all open sides.
- 12.3.6 Staging supports shall be All Purpose Scaffolding (APS) steel tubes scaffolding, safety secured and supported on firm level footings or slung from overhead beams. The supports shall be situated at maximum distance of 2.5 metres apart and the staging shall be secured to each support.
- 12.3.7 Wherever it is not possible to put up staging and/or use of safety belts, safety nets shall be slung beneath the place of work for safety.
- 12.3.8 When working over open process vessels or tanks, safety belts and safety nets shall always be used whether or not staging and scaffolding is provided.
- 12.3.9 Safe access to all points of works shall be provided in the form of suitable ladders and stairways etc.
- 12.3.10 Area around the work place shall be barricaded suitably or fenced off to avoid injuries to personnel passing by. Suitable warning boards and signs shall be put up.

12.4 EXCAVATION

- 12.4.1 In the event of an excavation or removing a manhole cover, the CONTRACTOR shall ensure that any opening, sump or pit caused is securely fenced and covered as required by the Factory Act before leaving the workplace for the day.
- 12.4.2 Suitable warning boards and signs shall be put up near such opening while work is in progress to warn persons passing by.

12.5 LIFTING GEAR



12.5.1 The CONTRACTOR shall submit a valid Test Certificate to the or OWNER , from approved certifying authorities for all of his lifting gear and hoists, slings, chains, wire ropes, hooks, chain-pulley blocks, winches, hoists and cranes etc. before commencing work.

12.5.2 These certificates shall be available at site in the CONTRACTOR's office for inspection as and when required.

12.6 PRESSURE AND LEAK TESTING

12.6.1 Pressure and leak testing of equipment shall be carried out hydraulically. However, in special cases where pneumatic testing is specified, written approval shall be obtained from the OWNER before starting work. Under no circumstance gases other than nitrogen, carbon dioxide, air or steam shall be used for testing.

12.6.2 In case nitrogen or carbon dioxide is used for testing, the equipment shall be adequately ventilated and gas tested to ensure oxygen content of 21% before permitting a worker to enter the equipment.

12.7 WORK INSIDE AN EQUIPMENT OR DRAINAGE SYSTEM

12.7.1 All equipment and associated piping shall be isolated, completely drained, purged and well ventilated before entry of a worker. The atmosphere inside the vessel or equipment shall be tested to ensure absence of toxic and flammable gases.

12.7.2 Toxic and flammable liquids and gases in the equipment shall be safely disposed off as per the statutory requirements to the satisfaction of the OWNER.

12.7.3 Workers carrying out drainage, purging and testing operations shall wear gas masks and other protective gear appropriate to the material being handled.

12.7.4 While a worker has entered equipment or a drainage system, another worker shall be present outside at all times to assist the worker inside in the event of an emergency.

12.8 ELECTRICAL

12.8.1 Portable power tools rated for above 50 V supply and hand lamps rated for above 24 V supply shall not be used at site.



12.8.2 An armoured cable with a 3 pin Rey Rolle type plug, properly earthed shall be provided between the CONTRACTOR's DG set and step down transformer.

12.8.3 All power supply and distribution boards shall have canopy for protection and all the distribution boards shall be earthed securely.

12.8.4 All supply points shall have proper plug and socket.

12.8.5 The CONTRACTOR shall check tightness of connection of cable terminations and joints before starting the work.

12.9 WELDING

12.9.1 Only qualified welders shall be employed at the work site. The CONTRACTOR shall organise the qualifying test at site for his welders and the OWNER shall approve the welders. All welders shall have to undergo qualifying test and only on passing the test, they shall be allowed to work at site.

12.9.2 For all welding work at site, generator sets shall be used instead of AC transformer sets. AC transformer sets are banned for welding jobs inside vessels (both open and closed top type).

12.9.3 The CONTRACTOR shall get his welding sets certified by the OWNER before starting work. These certificates shall have to be renewed every two months. A copy of the certificates shall be displayed on respective welding sets.

12.9.4 Only cables in good condition and insulated holders shall be used. The length of supply cable to welding site shall not exceed 8 metres and the welding set body shall be properly earthed.

12.9.5 A charged fire extinguisher of CO2 type shall be carried with each welding set. The CONTRACTOR shall keep Halon or equivalent type fire extinguishers near hot jobs like cutting oil lines.

12.9.6 The welder shall not use a building structure, pipeline or railway track etc. as a return path of the current. Adequately rated circuit breaker shall be provided in the power circuit for human protection on all power supply points.

12.10 HOT WORK

12.10.1 Before starting any hot work like gas cutting, welding and grinding etc., the



CONTRACTOR shall obtain hot work permit from the or OWNER . The permit shall be renewed on day-to-day basis.

12.10.2 The CONTRACTOR shall ensure purging of piping and equipment to make it totally safe before carrying out any hot work.

12.10.3 Smoking is strictly prohibited in work areas inside the press premises. Smoking is strictly prohibited even in areas not marked by the sign boards.

12.10.4 No combustible material shall be stored on or near any source of heat like hot pipes, welding or gas. Before leaving the place of work or the CONTRACTOR's sheds, the CONTRACTOR's workmen shall ensure that no material or item that could start a fire is left at site. Special attention shall be paid to collection and disposal of oil soaked cotton waste or rags. On no account are these to be dropped into corners, pushed below equipment or left hanging on pipes.

12.10.5 Gas cylinders shall be used in a safe manner. These shall not be dropped from heights or dragged on the floor. Trolley with rubber rimmed wheels shall be used for transporting gas cylinders within the site. Acetylene cylinders shall be kept in upright position. Oxygen cylinders shall not be kept near inflammable materials like oil etc.

12.10.6 Tarpaulins shall not be used in the vicinity of welding and gas cutting jobs.

12.10.7 The CONTRACTOR's supervisor of the rank of a foreman or equivalent shall examine the arrangements made for hot work before commencement of work and shall satisfy himself that all reasonable safety precautions have been taken.

12.10.8 The CONTRACTOR shall return the hot work permit after completion of welding work.

12.11 PERSONAL PROTECTIVE EQUIPMENT

12.11.1 Workmen shall wear protective clothing, head, leg and eye protection safety equipment at all times as per the job requirements. These are to be supplied and provided by the CONTRACTOR.

12.11.2 Adequate number of IS approved safety helmets shall be available at site.



12.11.3 Welders shall wear good quality insulated welding gloves, goggles, face shield, shoes and overalls while at work.

12.12 ACCIDENTS

In case of injury or serious illness of a worker, the OWNER shall be notified immediately. All accidents shall be recorded by filling in the 'Accident Report' form, which shall be kept in easy accessible location in the site office of the CONTRACTOR. Any 'Near Miss' incident shall also be reported by the CONTRACTOR and recorded.

12.13 INSURANCE

All the CONTRACTOR's workmen shall be covered under the Employees State Insurance Scheme, Janata Policy or any other scheme which may be specified by the Statutory Authorities from time to time.

12.14 REVIEW MEETING

The or OWNER shall conduct fortnightly Safety Review Meeting to review the safety conditions practised at work areas by the CONTRACTOR.

12.15 WORK AFTER NORMAL WORKING HOURS

12.15.1 Extra care shall be taken for jobs to be carried out after normal working hours with due revalidated work permit and supervised by the CONTRACTOR's site in-charge. The site-in-charge shall make available his residential address and telephone number to the OWNER so that he can be contacted in case of an emergency.

12.15.2 Proper lighting shall be ensured at the workplace for any work carried out after the normal working hours.

12.16 CONVEYANCE FOR EMERGENCY

The CONTRACTOR shall ensure that conveyance and person with driving license is available at site at all times of work execution so that in case of an accident, the victim can be rushed to nearest medical centre.

12.17 SAFETY PRACTICES

12.17.1 Avoid working under un-insulated live conductors or working on freshly painted steel, which is still wet.



12.17.2 Stairs and railing shall be in place as long as necessary. Ladders shall be periodically checked for any defects. Ladders shall be securely fastened to prevent movement while in use.

12.17.3 The CONTRACTOR shall advise his workmen to take the following precautions while using ladders:

- (a) While ascending or descending, face the ladder. Use both hands for holding.
- (b) Do not climb higher than the third rung from top on straight or extension-ladders and second rung from top on set ladders.
- (c) Step-ladders shall be fully open before use.
- (d) Sliding down a ladder shall be prohibited.
- (e) Make shift ladders such as clear fastened across a single rail and short ladders spliced together shall never be used.
- (f) Ladders shall be kept free from dirt and grease.
- (g) Defective ladders shall be removed from use.
- (h) Ladders shall not be left un-attended unless these are securely anchored at top and bottom.
- (i) While using ladders, shoes shall not be greasy, muddy or otherwise slippery.
- (j) Ladder shall not be used during severe windy conditions.

12.17.4 Lumber shall be piled out of the work area. Nails shall be removed or bent while handling lumber to avoid injury to workmen.

12.17.5 While tearing down plaster or brickwork, dust shall be controlled with water.

12.17.6 Walls shall not be subjected to lateral pressure or impact from materials stored or falling materials.

12.17.7 The safety valves for boilers shall be set by trained personnel and shall be sealed or padlocked at safe working pressure. Only authorised person shall change the setting of safety valves. The safety valve relieving pressures shall be checked as



recommended by the manufacturer and applicable codes.

12.17.8 Blow down valves shall be operated strictly as per instructions. If blow cock is not marked with an arrow to show open and close position, the same shall be marked at site.

12.17.9 Safety slogans and safety instructions shall be prominently displayed in English, Hindi and local language at strategic locations.

12.18 EMERGENCY PROCEDURES

12.18.1 The CONTRACTOR shall familiarize himself with the emergency procedures, which apply to plants and areas in which his men are working.

12.18.2 First Aid Box shall be kept in the CONTRACTOR's site office. The CONTRACTOR's site-in-charge and his key supervisors shall be trained in administering first aid, preliminary treatment for electrical shocks, fall from height and burns etc.

12.18.3 When an emergency condition exists or on hearing the 'Stop Work Alarm' every supervisor shall ensure:

- (a) All work is stopped at once.
- (b) All equipment is shutdown.
- (c) All men are evacuated to a pre-determined assembly point.
- (d) A roll call is taken and every man is accounted for.
- (e) No one shall be permitted to return to work until notification has been received from a responsible authorised agency that it is safe to do so.

12.19 RESPONSIBILITY OF THE CONTRACTOR'S SITE IN CHARGE

His primary responsibility is safety of personnel and equipment. He shall:

12.19.1 Understand the company's policy on maintaining safe working environment and appreciate the responsibility allocated to each grade of supervision.

12.19.2 Know the safety requirements and relevant Government Regulations, and ensure their implementation.



12.19.3 Ensure that sound, safe working methods and reasonable welfare facilities are provided for workers.

12.19.4 Determine at the planning stage the following:

- (a) The most appropriate order and method of working
- (b) Allocation of responsibilities to supervisors
- (c) Storage areas and access etc.
- (d) Hazards which may arise from overhead or underground services
- (e) Facilities for welfare, first aid and sanitation
- (f) Work permit procedures and requirements
- (g) Basic fire precautions
- (h) Provide written instructions to establish work methods, to explain the sequence of operations, to outline potential hazards at each stage and to indicate precautions to be adopted.



13. Proforma of Bank Guarantee for Security Deposit:

NO.
DATE:

..... (Insert: Bank's Name, and Address of Issuing Branch or Office)

Beneficiary:

Bank Note Paper Mill India Private Limited
Note Mudran Nagar,
Mysore 570003

Date:.....

Performance Guarantee No.:

WHEREAS.....(name and address of the contractor) (hereinafter called "the contractor") has undertaken, in pursuance of LOI (Letter of Intent) no..... dated to construction of proposed Construction of Armoury House for CISF (description of work) (herein after called "the contract").

AND WHEREAS it has been stipulated by you in the said LOI that the contractor shall furnish you with a bank guarantee by a scheduled commercial bank recognized by you for the sum specified therein as security for compliance with its obligations in accordance with the LOI;

AND WHEREAS we have agreed to give the contractor such a bank guarantee;

NOW THEREFORE we hereby affirm that we are guarantors and responsible to you, on behalf of the contractor, up to a total of..... (amount of the guarantee in words and figures), and we undertake to pay you, upon your first written demand declaring the contractor to be in default under the contract and without cavil or argument, any sum or sums within the limits of (amount of guarantee) as aforesaid, without your needing to prove or to show grounds or reasons for your demand or the sum specified therein.

We hereby waive the necessity of your demanding the said debt from the contractor before presenting us with the demand. We further agree that no change or addition to or other modification of the terms of the contract to be performed thereunder or of any of the contract documents which may be made between you and the contractor shall in any way release us from any liability under this guarantee and we hereby waive notice of any such change, addition or modification.

We undertake to pay Bank Note Paper Mill India Private Limited up to the above amount upon receipt of its first written demand, without Bank Note Paper Mill India Private Limited having to substantiate its demand.



This guarantee will remain in force for a period of sixty days after the completion of this contract and any demand in respect thereof should reach the Bank not later than the above date.

.....
(Signature of the authorized officer of the Bank)
Name, authorisation/ signature no. and designation of the officer
Seal, name & address of the Bank and address of the Branch

Checklist for Bank Guarantee:

EMD / Performance BG should be in line with / comply the following.

1. BG should be issued on not less than Rs.200 e stamp / non-judicial stamp paper only
2. Non judicial stamp paper / e stamp paper should be purchased in the name of BG issuing bank only.
3. In case of e stamp paper first party should be BG issuing bank and second party should be BNPM.
4. Date of sale of non-judicial / e stamp paper shown on the BG and the stamp paper (BG) issued is not more than six months prior to the date of execution of BG.
5. Executing officer of BG should indicate his name, designation and power of attorney number / signing power no etc. on each page of BG.
6. Name and address of the bidding party, name and address of BNPM and value of the contract are to be mentioned clearly.
7. Overwriting / cutting if any in BG should be authenticated under signature and seal of authorized signatory of BG issuing Bank.
8. BG number and BG date should be mentioned in all pages of BG and all pages are endorsed / signed by authorized signatories of issuing bank.
9. Amount mentioned in figures and words are to be matched.
10. Validity of BG should be in line with the contract.
11. BG should be unconditional.



14. Proforma of Bank Guarantee for EMD:

NOT APPLICABLE



15. SCHEDULE OF DEVIATIONS FROM GENERAL CONDITIONS

The BIDDER shall indicate below all deviations from the General Conditions.

SL. NO.	SECTION	SPECIFICATION NO.	PARA NO.	DEVIATION
1.				
2.				
3.				
4.				
5.				
6.				
7.				
8.				
9.				
10.				

The BIDDER hereby certifies that the above mentioned are the only deviations from the General Conditions for this Enquiry Document. The BIDDER further confirms that in the event any other data and information presented in the BIDDER's proposal and accompanying documents including drawings and catalogues etc. are at variance with the specific requirements laid out in the General Conditions, the latter shall govern and shall be binding on the BIDDER without any price implication.

COMPANY SEAL	SIGNATURE	
	NAME	
	DESIGNATION	
	COMPANY	
	DATE	



SCHEDULE OF PRICE

Prices are to be quoted in the price bid format given in the e-tender website (www.tenderwizard.com/BNP) only.

Blank copy (Without price) of this schedule of price duly signed & stamped on each page has to be uploaded along with technical document.

Enclosed as Annexure-1



TENDER FOR CONSTRUCTION OF WATCH TOWER AT BNPM PREMISES, MYSORE					
PRICE BID					
BNPM/TEN/392/watchtower/2018-19 Dated 06.08.2018					
SI NO	Description	Unit	BOQ	Rate in Rs.	Amount in Rs
1	Earth work excavation for foundation of structures upto 3m by mechanical means as per drawing and technical specification, including setting out, construction of shoring and bracing, removal of stumps and other deleterious matter, dressing of sides and bottom, filling back the excavation earth to the extent required and utilising/ transporting the remaining earth upto 1 km lead including the cost of labour, material and HOM of machineries etc. complete.				
a	do- Ordinary/Hard soil-Mechanical Means	cum	30		
b	do - Ordinary Rock (not requiring blasting) - Mechanical Means	cum	20		
2	KSRB 2-1.1 : Earthwork in surface excavation in ordinary soil for levelling and lowering the ground manually (other than foundation of buildings, culverts, road drains and trenches of pipe lines and cables) and removing the excavated stuff to a distance not exceeding 50m and lift upto 1.5m, excavated surface levelled and neatly dressed, disposed earth to be levelled after breaking of clods and neatly dressed as per specifications. Specification No. KBS 2.1(a) / 2.3.1	cum	30		
a	KSRB 2-1.1 : -do - Hard soil	cum	30		
3	KSRB 2.3 : Filling available excavated earth (excluding rock) in sides of foundations upto plinth in layers not exceeding 20 cms. in depth, compacting each deposited layer by ramming after watering with lead upto 50m. and lift upto 1.5m. including cost of all labour complete as per specifications. Specification No. KBS 2.9	cum	30		
4	KSRB 2.8 : Providing and filling in foundation with granite / trap broken metal 100mm. and down size, with approved sand including hand packing, ramming, watering, including cost of all materials and labour with all lead and lift, complete as per specifications. Specification No. KBS	cum	20		
5	KSRB 2.9 : Spreading and forming the excavated earth to required level, slope for an average thickness of 75mm, in all classes of soils including breaking clods and tamping manually around the building and low laying areas complete as per specifications. Specification No. KBS	sqm	30		
6	Laying dry stone Rubble soling with maximum 230mm size hard stone set in regular lines, hand packed and interstices thoroughly filled with small chips including filling in with good quality murum brought from outside and compacted with 1 to 10 ton rollers and spreading 12 mm layer of grit on top etc complete as directed by Engineer In Charge	cum	5		
7	KSRB-4.1.1: Providing and laying in position plain cement concrete of mix 1:2:4 with OPC cement @ 240 kgs, with 40mm and down size graded granite metal coarse aggregates @ 0.878 cum and fine aggregates @ 0.459cum machine mixed, concrete laid in layers not exceeding 15 cms. thick, well compacted, in foundation, including cost of all materials, labour, HOM of machinery, curing complete as per specifications. specification No. KBS 4.1, 4.2	cum	3		
8	KSRB 4.2.1: Providing and laying in position reinforced cement concrete of Design mix M25 with OPC cement @ 340 kgs, with 20mm and down size graded granite metal coarse aggregates @ 0.70cum and fine aggregates @ 0.47cum, with super plasticiser @ 3 liters conforming to IS9103-1999 Reaffirmed-2008 at machine mixed, concrete laid in layers not exceeding 15 cms thick, vibrated for all works in foundation for footings, pedestals, retaining walls, return walls, walls (any thickness) including attached pilasters, columnpillars, posts, struts, buttresses, bed blocks, anchor blocks & plinth etc., including cost of all materials, labour, HOM of machinery, curing, complete but excluding cost of reinforcement as per specifications. (Excluding cost of steel, fabrication and finishing charges) Specification No. KBS 4.1, 4.6	cum	5		
9	KSRB 4.2.7: Providing and laying in position reinforced cement concrete of design mix M25 with OPC cement @ 340 kgs, with 20mm and down size graded granite metal coarse aggregates @ 0.70cum and fine aggregates @ 0.47cum with superplasticiser @3lts conforming to IS9103- 1999 Reaffirmed-2008, machine mixed, concrete laid in layers not exceeding 15 cms thick, vibrated for all works in ground floor level for roof slabs, staircase, lintles and beams retaining walls, return walls, walls (any thickness) including attached pilasters, columns, pillars, posts, struts, buttresses, string or lacing courses, parapets, coping, bed blocks, anchor blocks, plain window cills, fillets etc., including cost of all materials, labour, HOM of machinery, curing, complete but excluding cost of reinforcement as per specifications. (Excluding cost of steel, fabrication and finishing charges) Specification No. KBS 4.1, 4.6	cum	10		



10	KSRB 4-6.1: Providing and removing centering, shuttering, strutting, propping etc., and removal of form work for foundations, footings, bases of columns for mass concrete including cost of all materials, labour complete as per specifications. Specification No. KBS 4.6.2	Sqm	8		
11	KSRB 4-6.2: Providing and removing centering, shuttering, strutting, propping etc., and removal of form work for suspended floors, landings, balconies, stairs, cornice, mouldings, column, corbels, pillar post, of any shape/plan thickness upto 200 mm including cost of all materials, labour complete as per specifications for heights more than 3.50 from ground level. -do- 0 to 5 mtrs.	Sqm	10		
12	KSRB 4.9.2 : Providing mild steel reinforcement for R.C.C. work including straightening, cutting, bending, hooking, placing in position, lapping and / or welding wherever required, tying with binding wire and anchoring to the adjoining members wherever necessary complete as per design (laps, hooks and wastage shall not be measured and paid) cost of materials, labour, HOM of machinery complete as per specifications. Specification No. KBS 4.6.3 - do - TMT bars Fe 500	Tonne	2		
13	KSRB-6.1.3: Providing and constructing burnt brick masonry for basement and superstructure with approved quality of non-modular bricks of standard size of class designation 3.5 Newton per sqmm with cement mortar 1:6 including cost of materials, labour charges, scaffolding, curing complete as per specifications.	cum	10		
14	KSRB 15.3.5 Providing 15mm thick cement plaster in single coat with cement mortar 1:4, to brick masonry including rounding off corners wherever required smooth rendering, : Providing and removing scaffolding, including cost of materials, labour, curing complete as per specifications.	Sqm	40		
15	KSRB 15.3.10: Providing 20mm thick cement plaster in single coat with cement mortar 1:3, to brick masonry including rounding off corners wherever required smooth rendering, : Providing and removing scaffolding, including cost of materials, labour, curing complete as per specifications.	Sqm	40		
16	KSRB 15.4.1: Extra for providing and mixing waterproofing compound in cement plaster work at one kg per bag or in the proportion recommended by the manufactures, for cement mortar 1:3, 12mm thick cost of materials complete as per specifications.	Sqm	40		
17	Providing and fixing Vitrified glazed tiles of approved make, quality and colour of size 600 x 600 x 10mm thick fixed on bed of 12mm thick cement mortar for flooring, skirting and jointed with neat cement slurry mixed with pigment to match shade of tiles, including providing spacers at required interval and removing stains etc., complete as per specification.	Sqm	20		
18	KSRB 15-16.1 : Providing, applying and finishing external walls in two coats with waterproof cement paint of approved brand and shade to give an even shade after thoroughly brooming the surface to remove all dirt and loose powdered material, free from mortar drops and other foreign matter cost of materials, labour, complete as per specifications. _ do- with primer	Sqm	40		
19	KSRB 15-15.1 : Providing and applying painting in two coats with plastic emulsion paint of approved brand on wall surface to give an even approved shade after thoroughly brooming the surface, free from mortar drops and other foreign matter including preparing the surface even and sand paper smooth, cost of materials, labour, complete as per specifications. _do- with primer	Sqm	40		
20	KSRB 15.10.3 : Providing white washing to ceiling and / or slopping roof surface in two coats with lime of approved quality, to give an even shade including cost of materials, labour, complete as per specifications.	Sqm	16		
21	KSRB 7.11 : Providing and fixing of position aluminium window and ventilator as per approved drawings with sliding shutters using double track window frame section of size 61.85 x 31.75 m. with 1.2mm thick, bottom section 0.696kg/m, sides and top sections 1.30mm thick weight 0.659kg/m: and shutter comprising top and bottom section of size 40mm x 18mm, 1.25mm thick 0.417kg/m, shutter interlock section 40mm x 26.7mm, 1.1mm thick, weight 0.469kg/m. the shutters mounted on nylon roller with approved quality of fixtures such as aluminium handles tower bolts etc.: and providing and fixing 5.5mm. thick plain glass for shutters fitted with rubber beading aluminium sections including cutting to required length, joints mitred subdividing the frame tenoned and riveted in the assembled frame stiffened with end clips at corners angles ect, and fixed to the walls, lintels, floor beams/ cills as the case may be with necessary steel screws, raul plugs, or teak wood gatties including cutting masonry or concrete and making good the original surface using cement mortor, aluminium sections pretreated for removal of any specification No. KBS - do- using aluminium section anodized to 12-15 microns.	Sqm	18		

22	Supplying, Fabricating as per specifications and fabrication drawings, transporting to site and erecting structural steel members for all types of structure like staircase, door, window etc. as per the requirement for all heights & at all levels including provision of necessary erection bolts, aldrop, tower bolt, fixing bolts, nuts, washers, cleats, stiffeners, gussets, base plate, and all necessary operations but not limited to preheating as per specifications, straightening, bending, cutting, drilling, grinding, machining if specified, welding etc. complete (weight of the bolts and nuts and welds shall not be considered for payment) and painting of structural steel by applying one coat of zinc phosphate primer (shop coat) and one coat of Synthetic Enamel paint (after fabrication) and second coat of Synthetic enamel Paint (after erection) of approved manufacture, brand, colour and shade etc as per specifications at all elevation and as directed including supply of paint, cleaning and preparing the surface, scaffolding etc. complete.	Kg	500		
23	Providing and fixing 304 - grade stainless steel hand rails of 14-gauge pipes for Ramps or Staircase are made out of stainless steel hollow pipes, using 50mm dia for verticals @ 1.60 mtr c/c are fixed to the ramps or steps by drilling with bolts and 100mm dia MS base plates 10mm gauge for fixing of Vertical pipes 4 - Nos anchor bolts & 40mm dia pipes are fixed horizontally for 2-rows top, one pipes are fixed with vertical pipes another one are fixed with elbows and 25mm dia pipes are fixed horizontally for 2-rows below top measure @ equal intervals including cutting, welding, bending wherever necessary with suitable caps @ tops, bottoms & corners finishing with mat / shining etc., complete including cost and conveyance of all materials, labour for all items of work, HOM of equipment with all lead and lift, loading and unloading, transportation charges and all other incidental charges etc., complete as per specification and directions of the Engineer-in-charge of the work.	Sqm	15		
24	Providing and laying pattern flooring for staircase treads and rises using the kota flooring stone supplied by BNPM. The granite materials are laid on existing bed of CM 1:3 20 mm thick pointed with colour pigment, including full rounding for nosing, cutting to the shape and required size, complete required for completion of the work as per specifications.	Sqm	5		
Total (without taxes)					
<u>GST@18%</u>					
Total Inclusive of all taxes					
Note : Evaluation shall be done without considering the GST. GST is to be quoted in the column provided, if the same is not quoted (or left blank) it will be considered as the prices are inclusive of GST.					



**TECHNICAL SPECIFICATIONS
FOR
CIVIL WORKS**

1. GENERAL

a) The Technical Specifications in respect of all materials to be used, method of execution, workmanship and quality for each item of the work shall conform to the latest Indian Standard.

In case where the specifications in the drawings or those given in schedule of quantities are found wanting, the latest IS specifications shall hold good.

Whenever reference has been made to Indian Standard or any other specifications, same shall mean to refer to latest specifications irrespective of any particular edition in the specifications below or in schedule of quantities.

Works shall be carried in strict accordance with the relevant IS codes & item descriptions & its specification and as per the instructions of BNPM.

2. Workmanship

The workmanship shall be the best of its kind and shall conform to Specifications as per relevant Indian Standard Specifications in every respect or the latest trade practice and shall subject to the approval of the Architect. All materials and / or workmanship which in the opinion of the BNPM .MYSORE. /Architect is defective or unsuitable shall be removed immediately from the site and shall be substituted with proper materials and/ or workmanship forthwith

3. Materials

All materials shall be best of their kind and shall conform to the latest Indian Standards.

All materials shall be of approved quality as per samples and approved by the BNPM .MYSORE. .

A set of specimen samples of all approved materials shall be kept at site as well as in the office of the engineer, the cost of which to be borne by the contractor.

LIST OF APPROVED MAKE FOR CIVIL

1	Cement	ACC / Ultra Tech /L&T/ (OPC 43 grade and 53 grades) as per
2	Reinforcement Steel	TMT bars of Tata steel, SAIL/ RINL or Equivalent Approved by BNPM .MYSORE.
3	Structural Steel	Structural steel of Tata steel, SAIL/ RINL or Equivalent approved by BNPM .MYSORE.



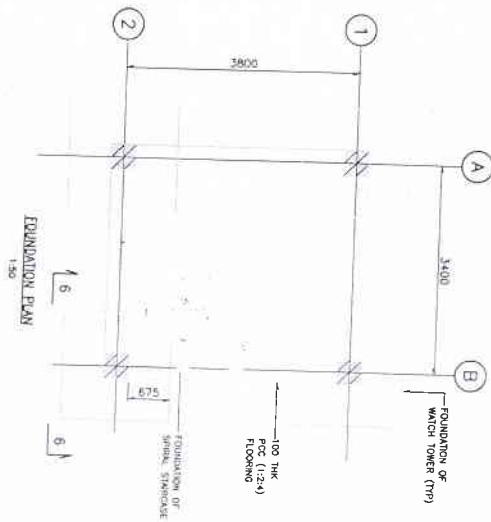
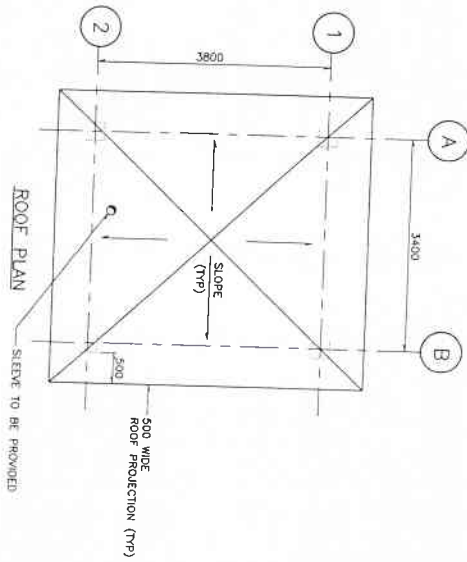
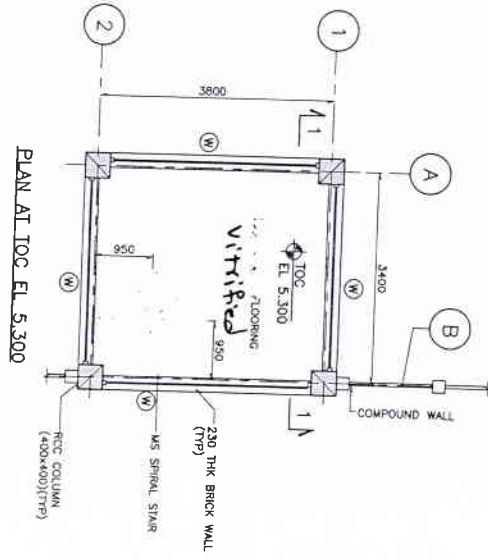

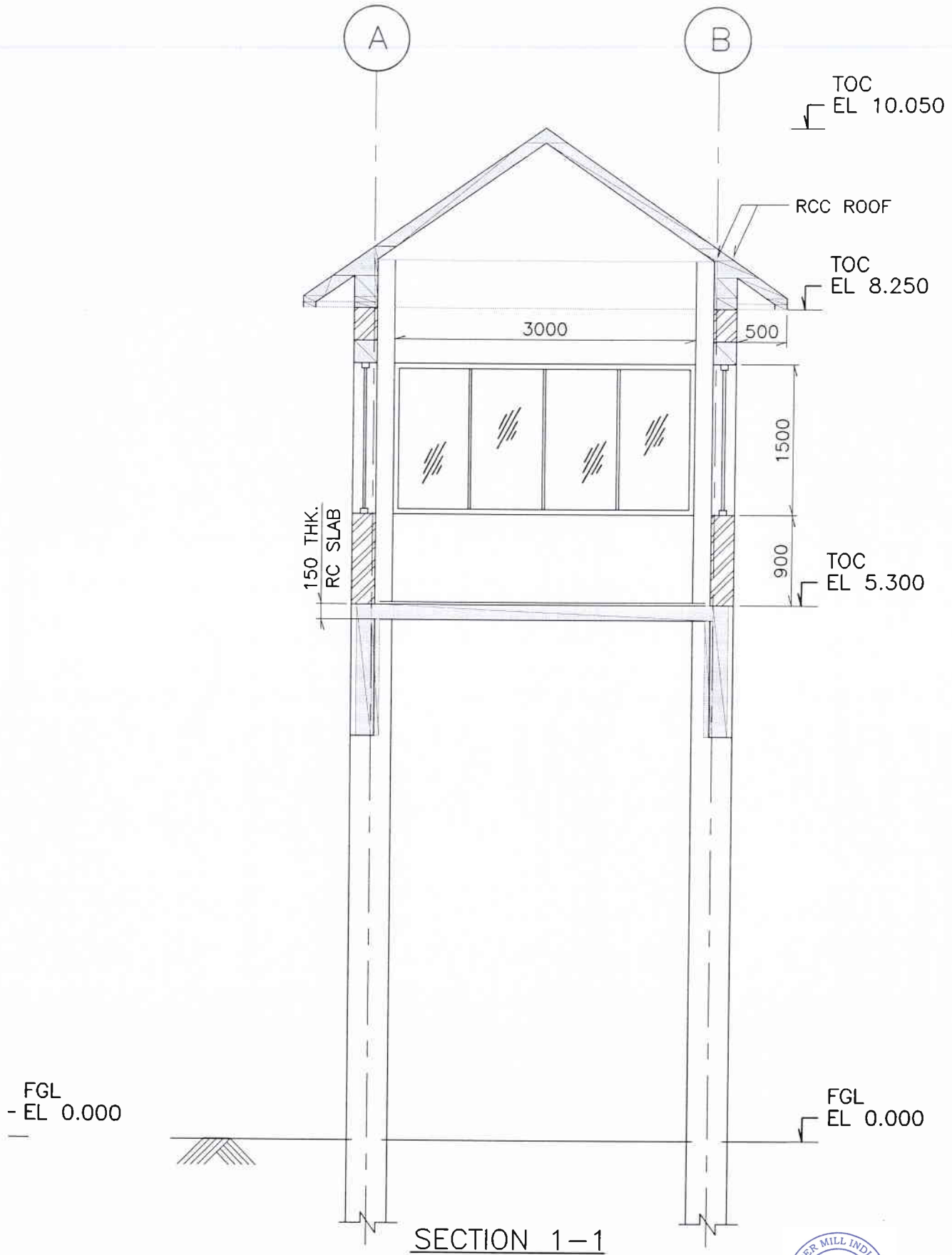

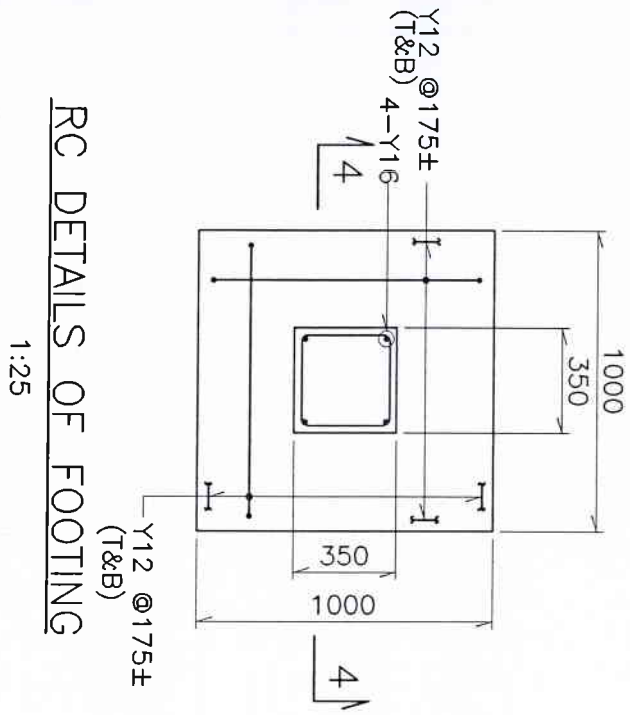

RC DETAILS OF FOOTING

1:25

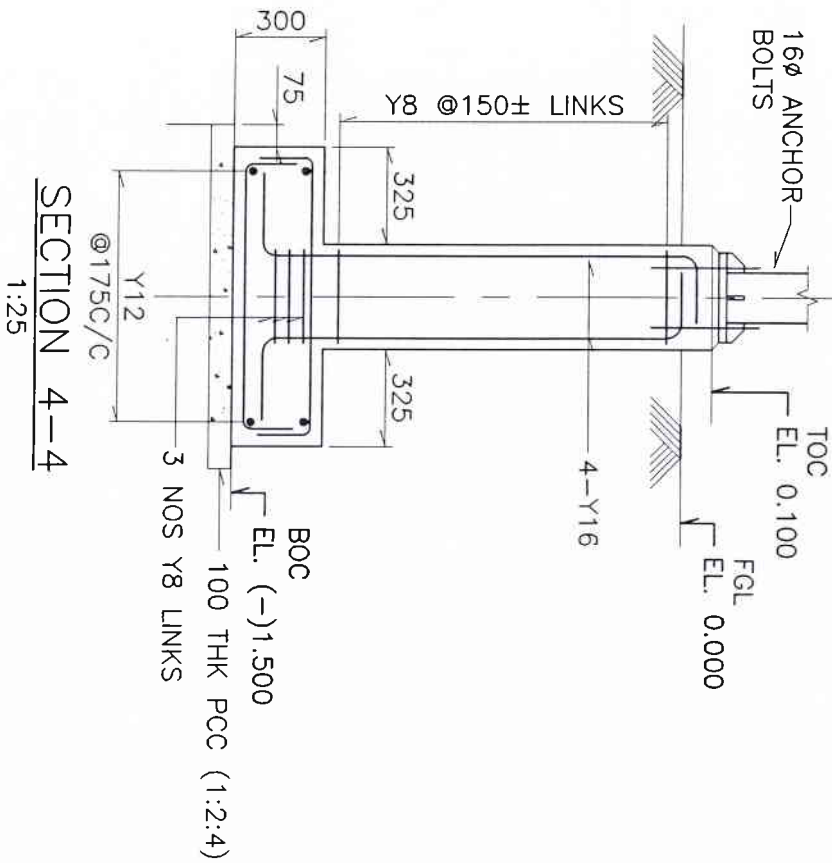

SECTION 4-4

1:25

